

SERVICE MANUAL

AA-2D CHASSIS

<u>MODEL</u>	<u>COMMANDER</u>	<u>DEST.</u>	<u>CHASSIS NO.</u>
KV-27S22	RM-Y135A	US	SCC-K96D-A
KV-27S22	RM-Y135A	CND	SCC-K97C-A
KV-27S26	RM-Y136A	US	SCC-K96P-A
KV-27S26	RM-Y136A	CND	SCC-K97L-A
KV-27S36	RM-Y136A	US	SCC-K96Q-A
KV-27S36	RM-Y136A	CND	SCC-K97M-A
KV-29PS2	RM-Y135A	MX	SCC-N02A-A
KV-29RS22	RM-Y135A	E	SCC-K98C-A
KV-29RS22C	RM-Y135A	E	SCC-K98B-A
KV-29RS26	RM-Y136A	E	SCC-K98M-A
KV-29RS26C	RM-Y136A	E	SCC-K98N-A
KV-29SD2	RM-Y135A	E	SCC-K98D-A

Note Adjustment Manual for this model is published separately

	Adjustment Manual
Part No.	9-965-829-01



RM-Y136A

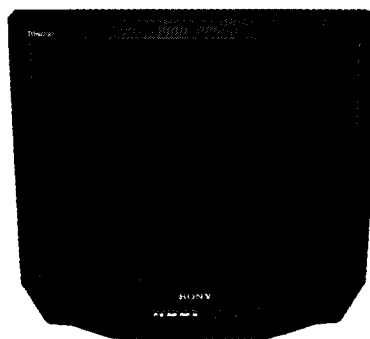

KV-27S36

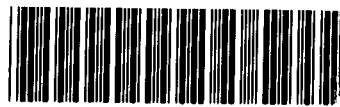

996583301

TRINITRON® COLOR TV
SONY®

SPECIFICATIONS

For all models:

Television system	American TV standard	
Channel coverage	VHF	2-13
	UHF	14-69
	CATV	1-125
Antenna	75-ohm external antenna terminal for VHF / UHF	
Picture tube	Hi-Black Trinitron® tube	

For specific models:

	KV-27S22/29PS2/ 29RS22/29SD2	KV-27S26/ 29RS26	KV-27S36	KV-29RS22C	KV-29RS26C
Screen Size (measured diagonally)	27 inch	27 inch	27 inch	27 inch	27 inch
Power requirements	120V, 60Hz	120V, 60Hz	120V, 60Hz	220V, 50/60Hz	220V, 50/60Hz
Number of inputs/outputs					
Video ⁽¹⁾	1	2	2	1	2
S video ⁽²⁾	0	1	1	0	1
Audio ⁽³⁾	1	2	2	1	2
Audio out ⁽⁴⁾	1	1	1	1	1
Speaker output (W)	5W x 2	5W x 2	5W x 2	5W x 2	5W x 2
Power consumption (W) When in use (Max.) In Standby	160W 9W	165W 9W	180W 9W	160W 9W	165W 9W
Dimensions (W/H/D) (mm)	660 4 x 602 5 x 521 2 mm	660 4 x 602 5 x 521 2 mm	660 4 x 602 5 x 521 2 mm	660 4 x 602 5 x 521 2 mm	660 4 x 602 5 x 521 2 mm
(in.)	26 x 23 ^{3/4} x 20 ^{5/8} in	26 x 23 ^{3/4} x 20 ^{5/8} in	26 x 23 ^{3/4} x 20 ^{5/8} in	26 x 23 ^{3/4} x 20 ^{5/8} in	26 x 23 ^{3/4} x 20 ^{5/8} in.
Mass (kg) (lb)	40 6 kg 89 lbs 8oz	41 kg 90 lbs 7oz	42 kg 92 lbs 10oz	40 6 kg 89 lbs 8oz	41kg 90 lbs 7oz
Supplied accessories Remote commander (w/ 2 size AA (R6) batteries)	RM-Y135A	RM-Y136A	RM-Y136A	RM-Y135A	RM-Y136A

⁽¹⁾ 1 Vp-p, 75 ohms unbalanced, sync negative

⁽²⁾ Y 1 Vp-p, 75 ohms unbalanced, sync negative C 0 286 Vp-p (Burst signal), 75 ohms

⁽³⁾ 500 mVrms (100% modulation), Impedance 47 kilohms

⁽⁴⁾ More than 408 mVrms at the maximum volume setting (variable)

More than 408mVrms (fix), Impedance 50 kilohms

**** Design and specifications are subject to change without notice**

Optional accessories

Connecting cables VMC-810S/820S, VMC-720M,

YC-15V/30V, RK-74A

TV Stand SU-27A

U/V mixer EAC-66

(●)® SRS (SOUND RETRIEVAL SYSTEM)

The (●) SRS (SOUND RETRIEVAL SYSTEM) is manufactured by Sony Corporation under license from SRS Labs, Inc. It is covered by U S Patent No 4,748,669. Other U S and foreign patents pending.

The word "SRS" and the SRS symbol (●) are registered trademarks of SRS Labs, Inc.

SAFETY CHECK-OUT (US Model only)

After correcting the original service problem, perform the following safety checks before releasing the set to the customer

- 1 Check the area of your repair for unsoldered or poorly-soldered connections. Check the entire board surface for solder splashes and bridges.
- 2 Check the interboard wiring to ensure that no wires are "pinched" or contact high-wattage resistors.
- 3 Check that all control knobs, shields, covers, ground straps, and mounting hardware have been replaced. Be absolutely certain that you have replaced all the insulators.
- 4 Look for unauthorized replacement parts, particularly transistors, that were installed during a previous repair. Point them out to the customer and recommend their replacement.
- 5 Look for parts which, though functioning, show obvious signs of deterioration. Point them out to the customer and recommend their replacement.
- 6 Check the line cords for cracks and abrasion. Recommend the replacement of any such line cord to the customer.
- 7 Check the B+ and HV to see if they are specified values. Make sure your instruments are accurate, be suspicious of your HV meter if sets always have low HV.
- 8 Check the antenna terminals, metal trim, "metallized" knobs, screws, and all other exposed metal parts for AC Leakage. Check leakage as described below.

LEAKAGE TEST

The AC leakage from any exposed metal part to earth ground and from all exposed metal parts to any exposed metal part having a return to chassis, must not exceed 0.5 mA (500 microampere). Leakage current can be measured by any one of three methods.

- 1 A commercial leakage tester, such as the Simpson 229 or RCA WT-540A. Follow the manufacturers' instructions to use these instructions.
- 2 A battery-operated AC milliammeter. The Data Precision 245 digital multimeter is suitable for this job.
- 3 Measuring the voltage drop across a resistor by means of a VOM or battery-operated AC voltmeter. The "limit" indication is 0.75 V, so analog meters must have an accurate low voltage scale. The Simpson's 250 and Sanwa SH-63Trd are examples of passive VOMs that are suitable. Nearly all battery operated digital multimeters that have a 2V AC range are suitable. (See Fig. A)

HOW TO FIND A GOOD EARTH GROUND

A cold-water pipe is guaranteed earth ground, the cover-plate retaining screw on most AC outlet boxes is also at earth ground. If the retaining screw is to be used as your earth-ground, verify that it is at ground by measuring the resistance between it and a cold-water pipe with an ohmmeter. The reading should be zero ohms. If a cold-water pipe is not accessible, connect a 60-100 watt trouble light (not a neon lamp) between the hot side of the receptacle and the retaining screw. Try both slots, if necessary, to locate the hot side of the line, the lamp should light at normal brilliance if the screw is at ground potential. (See Fig. B)

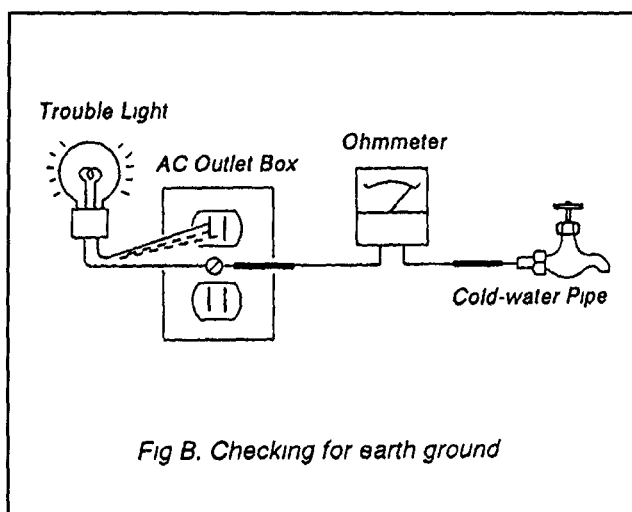
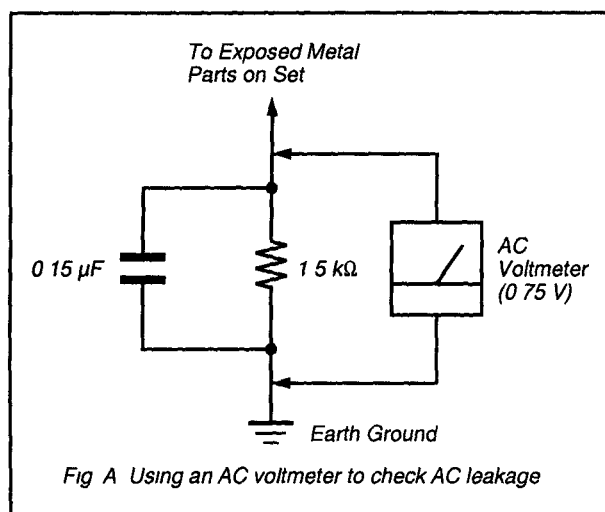

TABLE OF CONTENTS

<u>Section</u>	<u>Title</u>	<u>Page</u>	<u>Section</u>	<u>Title</u>	<u>Page</u>
1. GENERAL			2. DISASSEMBLY		
	Welcome!	5	2-1	Rear Cover Removal	12
	Connecting and Installing the TV	5	2-2	Chassis Assy Removal	12
	Connector Types	5	2-3	Service Position	12
	Making Connections	5	2-4	Picture Tube Removal	13
	Installing the glass door	7			
	Adjusting the shelf	7	3. SAFETY RELATED ADJUSTMENTS		14
	Basic Set up	7			
	Inserting Batteries	7	4. DIAGRAMS		
	Using the remote control/Select buttons	7	4-1	Block Diagram	19
	Adjusting slides	7	4-2	Circuit Boards Location	26
	On Line Help/Instructions	7	4-3	Printed Wiring Boards and Schematic Diagrams	26
	Using your New TV	8		• P Board (KV-27S26/27S36/29RS26/29RS26C)	27
	Setting up the TV automatically	8		• SC Board (KV-27S36 only)	30
	Watching the TV	8		• A Board	31
	Watching two programs at one time - PIP	8		• G Board	39
	Adjusting your SET UP (menus)	9		• C Board	41
	Learning menu selection	9		• UV Board (KV-27S36 only)	43
	Using the VIDEO menu	9		• AV Board (KV-27S36 only)	47
	Using the AUDIO menu	9	4-4	Semiconductors	49
	Using the TIMER menu	10			
	Using the SET UP menu	10	5. EXPLODED VIEWS		
	Operating Video Equipment	10	5-1	Chassis	50
	Setting the manufacturer's code	10			
	VCR manufacturer code numbers	10	6. ELECTRICAL PARTS LIST		51
	MDP manufacturer code numbers	10			
	Operating a cable box DBS receiver	11			
	Troubleshooting	11			

CAUTION!

SHORT CIRCUIT THE ANODE OF THE PICTURE TUBE AND THE ANODE CAP TO THE METAL CHASSIS, CRT SHIELD, OR CARBON PAINTED ON THE CRT, AFTER REMOVING THE ANODE

ATTENTION

APRES AVOIR DECONNECTE LE CAP DE L'ANODE, COURT-CIRCUITER L'ANODE DU TUBE CATHODIQUE ET CELUI DE L'ANODE DU CAP AU CHASSIS METALLIQUE DE L'APPAREIL, OU AU COUCHE DE CARBONE PEINTE SUR LE TUBE CATHODIQUE OU AU BLINDAGE DU TUBE CATHODIQUE

WARNING!!

AN ISOLATION TRANSFORMER SHOULD BE USED DURING ANY SERVICE TO AVOID POSSIBLE SHOCK HAZARD, BECAUSE OF LIVE CHASSIS
THE CHASSIS OF THIS RECEIVER IS DIRECTLY CONNECTED TO THE AC POWER LINE

ATTENTION!!

AFIN D'EVITER TOUT RESQUE D'ELECTROCUTION PROVENANT D'UN CHÂSSIS SOUS TENSION, UN TRANSFORMATEUR D'ISOLEMENT DOIT ETRE UTILISE LORS DE TOUT DEPANNAGE LE CHÂSSIS DE CE RÉCEPTEUR EST DIRECTEMENT RACCORDE À L'ALIMENTATION SECTEUR

SAFETY-RELATED COMPONENT WARNING!!

COMPONENTS IDENTIFIED BY SHADING AND MARK Δ ON THE SCHEMATIC DIAGRAMS, EXPLODED VIEWS AND IN THE PARTS LIST ARE CRITICAL FOR SAFE OPERATION REPLACE THESE COMPONENTS WITH SONY PARTS WHOSE PART NUMBERS APPEAR AS SHOWN IN THIS MANUAL OR IN SUPPLEMENTS PUBLISHED BY SONY CIRCUIT ADJUSTMENTS THAT ARE CRITICAL FOR SAFE OPERATION ARE IDENTIFIED IN THIS MANUAL FOLLOW THESE PROCEDURES WHENEVER CRITICAL COMPONENTS ARE REPLACED OR IMPROPER OPERATION IS SUSPECTED

ATTENTION AUX COMPOSANTS RELATIFS A LA SECURITE!!

LES COMPOSANTS IDENTIFIES PAR UNETRAME ET PAR UNE MARQUE Δ SUR LES SCHEMAS DE PRINCIPE, LES VUES EXPLOSEES ET LES LISTES DE PIECES SONT D'UNEIMPORTANCE CRITIQUE POUR LA SECURITE DU FONCTIONNEMENT NE LES REMPLACER QUE PAR DES COMPOSANTS SONY DONT LE NUMERO DE PIECE EST INDIQUE DANS LE PRESENT MANUEL OU DANS DES SUPPLEMENTS PUBLIES PAR SONY LES REGLAGES DE CIRCUIT DONT L'IMPORTANCE EST CRITIQUE POUR LA SECURITE DU FONCTIONNEMENT SONT IDENTIFIES DANS LE PRESENT MANUEL SUIVRE CES PROCEDURES LORS DE CHAQUE REMPLACEMENT DE COMPOSANTS CRITIQUES, OU LORSQU'UN MAUVAIS FONTIONNEMENT SUSPECTE

SECTION 1 GENERAL

The instructions mentioned here are partial abstracts from the Operating Instruction Manual. The page numbers shown reflect those of the Operating Instruction Manual.

Welcome!

Thank you for purchasing the Sony Trinitron® Color TV. This manual is written for the models listed below. Before reading, check the model number on the rear of your TV.

Model KV-27S26 is used for illustration purposes. The screens displayed are for model KV-35V36. Differences in operation features are indicated in the text, for example, "KV-27S26 only".

Model Number	Light sensor (TR channel TV only)	Light sensor (TV channel TV only)	TV conversion	Channel TV	Remote control
KV-27S26	○	○	○	○	○
29V36C	○	○	○	○	○
29V36D	○	○	○	○	○
29V36E	○	○	○	○	○
29V36F	○	○	○	○	○
29V36G	○	○	○	○	○
29V36H	○	○	○	○	○
29V36I	○	○	○	○	○
29V36J	○	○	○	○	○
29V36K	○	○	○	○	○
29V36L	○	○	○	○	○
29V36M	○	○	○	○	○
29V36N	○	○	○	○	○
29V36O	○	○	○	○	○
29V36P	○	○	○	○	○
29V36Q	○	○	○	○	○
29V36R	○	○	○	○	○
29V36S	○	○	○	○	○
29V36T	○	○	○	○	○
29V36U	○	○	○	○	○
29V36V	○	○	○	○	○
29V36W	○	○	○	○	○
29V36X	○	○	○	○	○
29V36Y	○	○	○	○	○
29V36Z	○	○	○	○	○

Precautions

Safety

- Operate the TV only on 120 V AC (except KV-29RS26C, 29V36C, 34RS26C, 34V36C).
- Operate the TV only on 220 V AC (KV-29RS26C, 29V36C, 34RS26C, 34V36C only).
- The plug is designed, for safety purposes to fit in the wall outlet only one way. If you are unable to insert the plug fully into the outlet, contact your dealer (except KV-29RS26C, 29V36C, 34RS26C, 34V36C).
- If any liquid or solid object should fall inside the cabinet, unplug the TV immediately and have it checked by qualified personnel before operating it further.
- If you will not be using the TV for several days, disconnect power by pulling the plug itself. Never pull on the cord.

Installing

- To prevent internal heat build-up, do not block the ventilation openings.
- Do not install the TV in a hot or humid place, or in a place subject to excessive dust or mechanical vibration.

For details concerning safety precautions see the supplied leaflet "IMPORTANT SAFEGUARDS".

Using This Manual

This manual is divided into four major sections. We recommend that you carefully review the contents of each section in the order provided to ensure that you fully understand the operation of your new TV.

- Connecting and installing the TV**
This section will guide you through your initial set up. It will show you how to connect your new components, connect your antenna or cable, and connect any accessories.
- Basic Set Up**
This section will teach you the basic skills needed to operate your new TV. It will show you how to operate special functions of the remote control.
- Using your New TV**
This section will show you how to begin using your new TV. It will show you how to use the AUTOSET UP feature and how to use your remote control's features.
- Adjusting your Set Up (menus)**
This section will teach you how to access on-screen menus and adjust your TV's settings.

Instructions in this manual are written for the remote control. Similar controls may be found on the TV console.

Connecting and Installing the TV

Making Connections

For best picture quality, a cable TV system or outdoor antenna is recommended.

Connecting directly to cable or an antenna

The connection you choose will depend on the cable found in your home. Newer homes will be equipped with standard coaxial cable (see A), older homes will probably have 300-ohm twin lead cable (see B). Still other homes may contain both (see C).

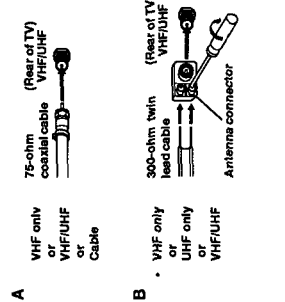

Connector Types

You may find it necessary to use some of the following connector types during set up.

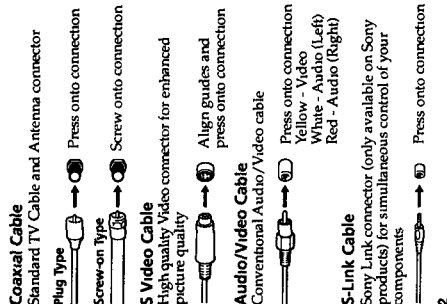

Connecting and installing the TV (continued)

Connecting an antennacable TV system with a VCR

- Attach the coaxial connector from your cable or antenna to IN on your VCR.
- Using AUDIO/VIDEO connectors, connect AUDIO and VIDEO OUT on your VCR to AUDIO and VIDEO IN on your TV (Yellow-VIDEO, White-AUDIO Left, Red-AUDIO Right).
- Using a coaxial connector, connect OUT on your VCR to VHF/UHF on your TV.

Connecting to an S Video equipped VCR (for optimum picture quality)

- Attach the coaxial connector from your cable or antenna to IN on your VCR.
- Using AUDIO connectors, connect AUDIO OUT on your VCR to AUDIO IN on your TV (White-AUDIO Left, Red-AUDIO Right).
- Using a coaxial connector, connect OUT on your VCR to VHF/UHF on your TV.
- Using an S VIDEO connector, connect S VIDEO on your VCR to S VIDEO on your TV.

If you are connecting a monaural VCR, connect only the single audio output to the left input on your TV.

Note on DVD Connection

- For the best picture quality, connect the DVD player directly to the TV.
- Refer to your DVD manual for detailed connection information.

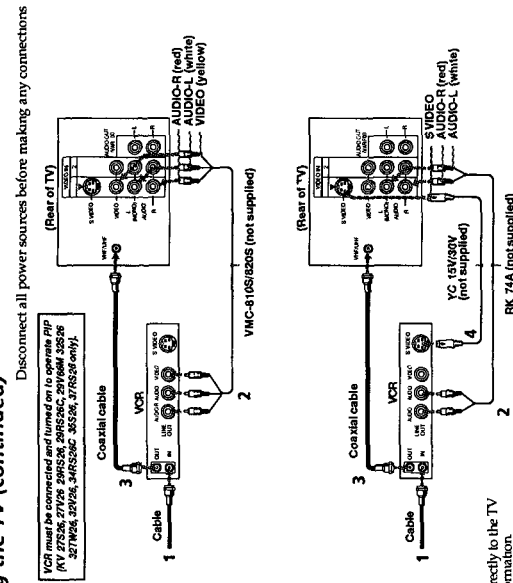

Precautions

Some pay cable TV systems use scrambled or unencoded signals that require a cable box to view all channels.

If you will be controlling all channel selection through your cable box, you should consider using the CHANNEL FIX feature discussed on page 22.

Cable box and cable

Some pay cable TV systems use scrambled or unencoded signals requiring a cable box only for certain channels (i.e. HBO SHOWTIME, etc).

Connecting a cable box

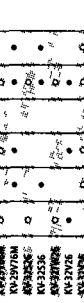

If you will be controlling all channel selection through your cable box, you should consider using the CHANNEL FIX feature discussed on page 22.

Cable and antenna

Most simple connection is made directly from the cable or antenna to the TV.

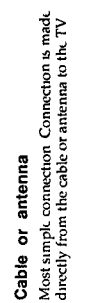

You may find it convenient to use the following set up if your cable provider does not feature local channels that you are able to receive using an antenna.

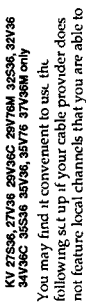

Set-Link Cable or ANT. mod. by pressing ANT on the TV remote control.

Connecting and Installing the TV (continued)

Connecting a DBS (Direct Broadcast Satellite) receiver

- 1 Connect the cable from your satellite antenna to your DBS receiver
- 2 Attach the coaxial connector from your cable or antenna to VHF/UHF on your TV
- 3 Using AUDIO/VIDEO connectors, connect AUDIO and VIDEO OUT on your DBS receiver to AUDIO and VIDEO IN on your TV

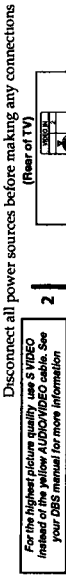

Disconnect all power sources before making any connections (Rear of TV)

For the highest picture quality use S VIDEO instead of the yellow AUDIO/VIDEO cable. See your DBS manual for more information.

Connecting a DBS (Direct Broadcast Satellite) receiver and a VCR

- 1 Connect the cable from your satellite antenna to your DBS receiver
- 2 Attach the coaxial connector from your cable or antenna to VHF/UHF-IN on your VCR
- 3 Using a coaxial connector, connect VHF/UHF-OUT on your VCR to VHF/UHF on your TV
- 4 Using AUDIO/VIDEO connectors, connect AUDIO and VIDEO OUT on your DBS receiver to AUDIO and VIDEO IN on your VCR
- 5 Using AUDIO/VIDEO connectors, connect AUDIO and VIDEO OUT on your VCR to AUDIO and VIDEO IN on your TV

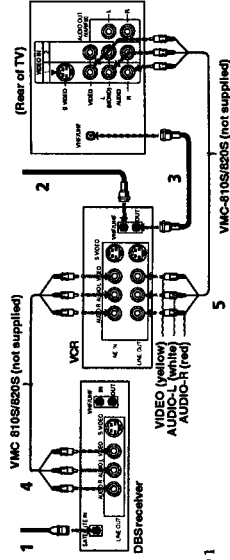

- Note**
- To view input from the DBS or VCR, select VIDEO 1 by pressing TV/VIDEO on the remote control

Connecting and Installing the TV (continued)

Connecting two VCRs for tape editing using MONITOR OUT

KV 27V36, 27V36C, 29V36C, 29V36M, 29V75M, 32V26, 32V36, 34V36C, 35V36, 35V76, 37V36M only

MONITOR OUT gives you the ability to use a second VCR to record a program being played by the primary VCR or to perform tape editing and dubbing

- 1 Connect the VCR intended for playback using the setup instructions on page 4 of this manual
- 2 Using AUDIO/VIDEO connectors, connect AUDIO and VIDEO IN on your VCR intended for recording to MONITOR AUDIO and VIDEO OUT on your TV

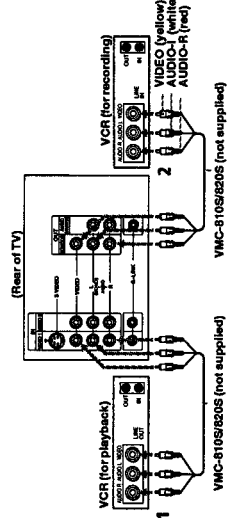

Notes

- Do not change the input signal while editing through MONITOR OUT
- When connecting a single VCR to the TV, if VCR LINE OUT is connected to TV VIDEO IN, do not connect the TV MONITOR OUT jack to the VCR LINE INPUT (see right). Doing so will cause program interference and other viewing problems

Connecting a VCR and TV with a cable box

- 1 Connect the single (input) jack of the Splitter to your incoming cable connection and connect the other two (output) jacks (using coaxial cable) to IN on your cable box and VHF/UHF on your TV
- 2 Using a coaxial connector, connect OUT on your cable box to IN on your VCR
- 3 Using AUDIO/VIDEO connectors, connect AUDIO and VIDEO OUT on your VCR to AUDIO and VIDEO IN on your TV (Yellow-VIDEO, White-AUDIO Left, Red-AUDIO Right)

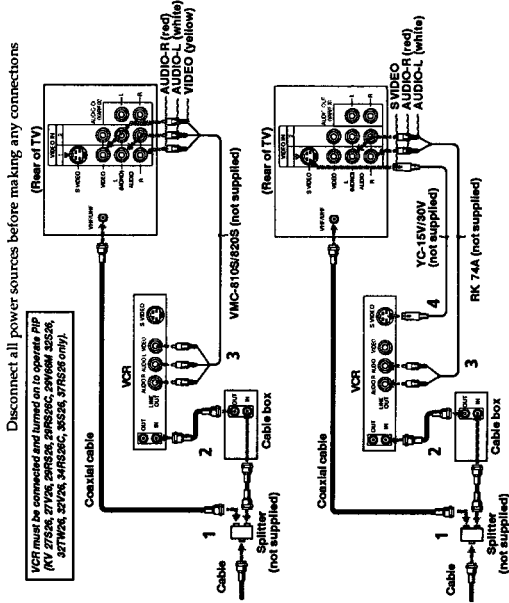

Disconnect all power sources before making any connections

VCR must be connected and turned on to operate. (KV 27V36, 27V36C, 29V36C, 29V36M, 29V75M, 32V26, 32V36, 34V36C, 35V36, 35V76, 37V36M only)

Connecting to an S Video equipped VCR with a cable box

- 1-2 Perform as described above
- 3 Using AUDIO connectors, connect AUDIO OUT on your VCR to AUDIO IN on your TV (White-AUDIO Left, Red-AUDIO Right)
- 4 Using an S VIDEO connector, connect S VIDEO on your VCR to S VIDEO on your TV

- Note**
- To view scrambled channels through your cable box, select VIDEO 1 by pressing TV/VIDEO on the remote control

Connecting an audio system

For greater viewing pleasure integrate your home stereo into the system

- 1 Using AUDIO connectors, connect AUDIO OUT on your TV to one of the unused Line inputs (e.g. Tape-2, etc) on your stereo (White-AUDIO Left, Red-AUDIO Right)
- 2 Set your stereo to the chosen Line input and refer to page 20 of this manual for additional audio setup instructions

Disconnect all power sources before making any connections

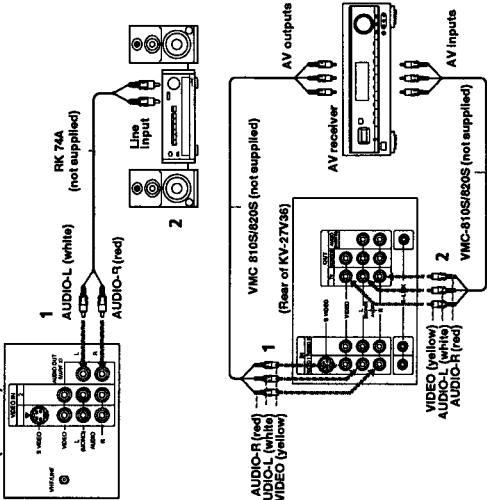

Connecting an AV receiver

KV 27V36, 29V36C, 29V75M, 32V36, 34V36C, 35V36, 35V76, 37V36M only

For greater viewing pleasure connect your AV receiver

- 1 Using AUDIO/VIDEO connectors, connect VIDEO 1 IN on your TV to Monitor AUDIO and VIDEO OUT on your AV receiver
- 2 Using AUDIO/VIDEO connectors, connect TV OUT on your TV to TV AUDIO and VIDEO IN on your AV receiver

You may want to use CHANNEL FIX for your TV's input to the AV receiver (VIDEO 1). See CHANNEL FIX page 22

Connecting and Installing the TV (continued)

KV-32TW26 and KV-35V76 only

Follow these instructions to install the glass door and adjust the shelf.

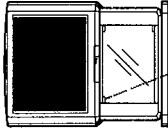

Push here to close
To open, push again

Parts List	Quantity
A Bottom hinge	1
B Top hinge	1
C Screw 4x4	4
D Plate pad	1
E Plate	1
F Metal pin	4

Disconnect all power sources before making any connections

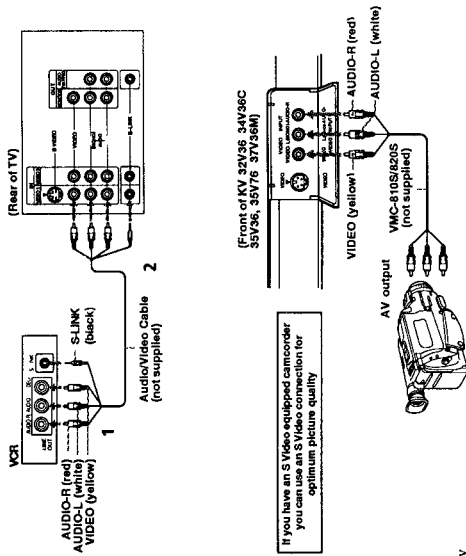

Using the S-Link function

KV-27V26, 27V36, 29V36C, 29V65M, 29V78M, 32V26, 32V36, 34V36C, 35V36, 35V76, 37V36M only

S-Link is a Sony innovation designed to make your Sony components work together. It allows you to automatically switch the TV input mode to video when you press PLAY on your Sony S-Link VCR. It also allows you to turn the VCR and TV off at the same time with the SYSTEM OFF button.

- 1 Connect your VCR using the setup instructions on page 4 of this manual.
- 2 Using an S-Link connector, connect the S-LINK jacks on your VCR and TV. Ensure that both ends are seated firmly and that the TV S-LINK connector is in the same row as the AUDIO/VIDEO connectors.

Connecting a camcorder

KV-27V26, 27V36, 29V36C, 29V65M, 29V78M, 32V26, 32V36, 34V36C, 35V36, 35V76, 37V36M only

This connection is convenient for viewing a picture directly from your camcorder.

Using AUDIO/VIDEO connectors, connect AUDIO and VIDEO OUT on your camcorder to AUDIO and VIDEO IN on the front panel of your TV (Yellow, Video, White-AUDIO Left, Red, AUDIO Right).

Note

- If you are connecting a monaural camcorder, connect only the single audio output to the left input on your TV.

Note

- Confirm that all parts are included before beginning assembly. If any parts are missing, contact your dealer.

Installing the glass door

- 1 Check that the projection of the screw through the bottom hinge, **A**, does not interfere with the proper installation of the hinge into the hole located at the bottom right side of cabinet.

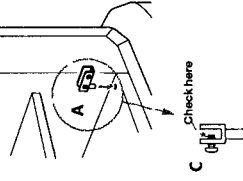

- 2 Attach the top hinge, **B**, to the right side of the glass door. Tighten the screws snugly but do not over-tighten. Attach the plate pad **D** to the left side and push the plate **E** over the plate pad.

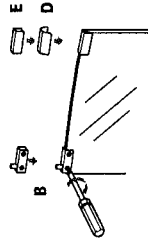

Basic Set up

Inserting batteries

Insert two size AA (R6) batteries (supplied) by matching the + and - on the batteries to the diagram inside the battery compartment.



Notes

- Remove the batteries to avoid damage from possible battery leakage, when ever you anticipate that the remote control will not be used for an extended period.
- Handle the remote control with care. Avoid dropping it, getting it wet, or placing it in direct sunlight, near a heater or where the humidity is high.
- Your remote control can be programmed to operate most video equipment. See page 24

Using the remote control

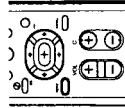

The supplied remote control has select buttons which allow for movement of the on screen selector in four directions. Pressing on the edge of the select buttons will cause the selector to move in the selected direction. Pressing the center of the select buttons will activate the selected item.

Adjusting sliders

When a menu item presents a slider (— or —) use the select buttons (← or →) to adjust the setting.

Adjusting the shelf

- 1 Press the upper part of the temporary shelf supports and remove the shelf.

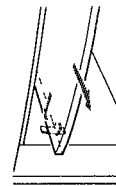

- 2 Insert the metal pin shelf supports (2 each side).

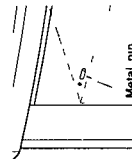

- 3 Push the top glass door hinge into the top right bushing and gently slide the glass door into the bottom hinge. Adjust the glass door until level and tighten the hinge screws.

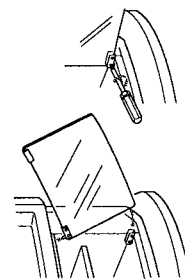

Using your New TV

Setting up the TV automatically

The EASY SETUP GUIDE feature will allow you to set the on-screen language and set all receivable channels. The EASY SETUP GUIDE screen will appear every time you turn on the TV until you perform AUTO PROGRAM.

The EASY SETUP GUIDE feature does not apply for installations that use a cable box for all channel selection.

To set up the TV manually refer to "Using the SET UP menu" on page 22.

Tips

- Perform the function that is indicated by the antenna and/or cable icon connected to the rear of the available channels will broadcast signals that are not receivable.
- After using EASY SETUP GUIDE you will still have the option of adjusting any of the system settings. Accessing channels through the SETUP menu (page 22).
- The TV must be set to TV input to execute AUTO PROGRAM. Press ANT until the channel number appears.
- If your cable or antenna is connected to AUX, then press ANT until AUX appears next to the channel number (KV 27S36 27V36 29V36C 29V76M 32S26 32V26 34V36C 35V36 35V76 37V36M only).

Using the buttons on the front of the TV



For KV-27V36 29V36C, 29V76M, 32V36, 34V36C, 35V36, 35V76 and 37V36M, the control buttons are located on the top of the TV.

- Press POWER to turn on the TV. The EASY SETUP GUIDE screen appears.

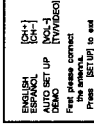

- Press POWER to turn on the TV. The EASY SETUP GUIDE screen appears. Press CHANNEL + to select English screens or CHANNEL - to select Spanish screens.



- Press VOLUME - to continue or TV/VIDEO for a DEMO of functions and menus.

Using your New TV (continued)

Watching the TV

All of the TV features can be accessed via the remote control. The following chart will explain the function of the buttons found on your remote control.

REFER TO THE ILLUSTRATION OF THE REMOTE CONTROL ON THE INSIDE FRONT COVER OF THIS MANUAL AS YOU REVIEW THIS CHART.

TV (FUNCTION)	Activates the remote control for use with the TV
TV POWER	Turns the TV on and off. If "VIDEO" appears on the screen, press TV/VIDEO or ANT so that a channel number appears.
0-9	Use for direct channel selection. Press 0-9 to select a channel (for example to select channel 10, press 1 and 0); the channel will change after 2 seconds or you can press ENTER for immediate selection.
CH +/-	Press to scan through the channels (+ up or - down).
VOL +/-	Press to adjust the volume (+ up or - down).
JUMP	Press to alternate or jump back and forth between two channels. You can only jump between the last two channels that have been selected with the 0-9 keys.
MUTING	Press to mute the sound ("MUTING" will appear on the screen). Press again or press VOL + to restore sound.
FREEZE	Press to freeze the window picture while in PIP mode. If you are not in PIP mode, pressing FREEZE will cause the main picture to freeze into a window picture. Great for copying down phone numbers, addresses, recipes, etc.

14

Using your New TV

Setting up the TV automatically

The EASY SETUP GUIDE feature will allow you to set the on-screen language and set all receivable channels. The EASY SETUP GUIDE screen will appear every time you turn on the TV until you perform AUTO PROGRAM.

The EASY SETUP GUIDE feature does not apply for installations that use a cable box for all channel selection.

To set up the TV manually refer to "Using the SET UP menu" on page 22.

Tips

- Perform the function that is indicated by the antenna and/or cable icon connected to the rear of the available channels will broadcast signals that are not receivable.
- After using EASY SETUP GUIDE you will still have the option of adjusting any of the system settings. Accessing channels through the SETUP menu (page 22).
- The TV must be set to TV input to execute AUTO PROGRAM. Press ANT until the channel number appears.
- If your cable or antenna is connected to AUX, then press ANT until AUX appears next to the channel number (KV 27S36 27V36 29V36C 29V76M 32S26 32V26 34V36C 35V36 35V76 37V36M only).

13

Using your New TV (continued)

Watching two programs at one time — PIP (Except KV-27S22/29RS22C/29RS22/29SD2/29PS2)

The Picture-in-Picture (PIP) feature allows you to view two channels simultaneously, one in the full size main picture and one in a smaller window picture. This means that two separate tuners must be available to provide the two signals.

REFER TO THE ILLUSTRATION OF THE REMOTE CONTROL ON THE INSIDE FRONT COVER OF THIS MANUAL AS YOU REVIEW THIS CHART.



Certain models (KV-27S26, 27V26, 29RS26, 29RS26C, 29V66M, 32S26, 32V26, 34RS26C, 35S26, 37RS26 only) are equipped with a single tuner. This simply means that a VCR must be connected and turned on for PIP to operate.

Tip

To measure correct single tuner PIP connection (KV 27S26 27V26 29RS26 29RS26C 29V66M 32S26 32V26 34RS26C 35S26 37RS26 only) make sure the following link sample connections.com please before using PIP.

- A cable or antenna is connected to the VCR.
- The VCR is connected to your TV.
- The VCR is turned on.

(for detailed connection information see page 3-5)

Note

- You must press TV (FUNCTION) before you can control PIP with the yellow-labeled buttons.

16

CAPTION VISION



Some programs are broadcast with Caption Vision. To display Caption Vision, select CC1, CC2, CC3, CC4, TEXT1, TEXT2, TEXT3, or TEXT4 from the menu, then press DISPLAY until Caption Vision is displayed.

CC1, CC2, CC3, or CC4 shows you a caption that is a printed version of the dialogue or sound effects of a program. (The mode should be set to CC1 for most programs.) TEXT1, TEXT2, TEXT3, or TEXT4 shows you text that is information presented using either half or the whole screen. It is not usually related to the program.

Notes

Poor reception of TV programs can cause errors in Caption Vision and XDS. Captions may appear with a white box or other errors instead of intended text. XDS Caption Vision and the status display cannot be used at the same time.

15

SLEEP	Press repeatedly until the TV displays the approximate time in minutes (30, 60 or 90) that you want the TV to remain on before shutting off automatically. Cancel by pressing until "SLEEP OFF" appears.
DISPLAY	Press repeatedly to step through available displays. Channel number, current time, channel caption (if set), and MTS mode (if SAP is selected) are displayed. SAP indication disappears after three seconds. XDS (Extended Data Service) shows a network name, program name, program type, program length, call letters, and time of the show if the Caption Vision service is available. Caption Vision will be displayed on the screen if the broadcaster offers this service. (see right). To cancel the display, press DISPLAY repeatedly until "DISPLAY OFF" appears. "DISPLAY OFF" disappears after three seconds.
TV/VIDEO	Press repeatedly to step through available video inputs. TV, Video 1 and Video 2 (KV-27S26 27V36 29RS26 29RS26C 32S26 32V26 34RS26C 35S26 37RS26 only). TV, Video 1, Video 2 and Video 3 (KV-27V26 27V36 29V36C 29V66M 29V76M 32V26 32V36 34V36C 35V36 35V76 37V36M only).
ANT	Press to change the VIDEO input to the AUX input (KV-27S36 27V36 29V36C 29V76M 32S26 32V26 34V36C 35S36 35V36 35V76 37V36M only). For detailed connection information, see "Cable box and cable or Cable and antenna" on page 3.
SYSTEM OFF	KV-27V26 27V36 29V36C 29V66M 32V26 32V36 34V36C 35V36 35V76 37V36M only. Press to turn off the TV and all other equipment connected with S-Link and return the TV input to either antenna or AUX, whichever was last used.
MTS/GUIDE	Press this button to cycle through the Multi-channel TV Sound (MTS) options. (page 20)

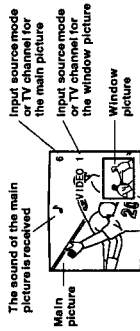

Use the Yellow Labeled Buttons for PIP Operations.

PIP	Press once to display the window picture (1/9 size). Press again to reduce the size of the window picture (1/16 size). Press a third time to remove the window picture.
TV/VIDEO	Press repeatedly to step through available video inputs. TV, Video 1, Video 2, and Video 3 (KV-27V26 27V36 29V36C 29V66M 29V76M 32V26 32V36 34V36C 35V36 35V76 37V36M only). If you use one of the connections from page 4, your PIP input source is a VCR or cable box.
AUDIO	Press to alternate sound between the main picture and the window picture. A "J" will appear for a few seconds to indicate which picture is receiving sound.

Adjusting your SET UP (menus)

Learning menu selection

Use the MENU button to access a menu and use the Select buttons to alter settings. Use the following example to learn how to modify settings.

- 1 Press the MENU button. The main menu appears.

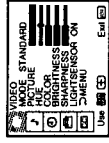

- 2 Press the select buttons (← or →) to highlight the desired menu and press (↵) to activate it.



- 3 Press the select buttons (← or →) to select the desired option.



- 4 Press (↵). Options for your selection will be displayed.



When you are done with changes to the selected menu, choose MENU to return to the main menu. Once you have completed all menu corrections, press MENU on the remote control to exit the menu screens.

Note

- Pressing MENU on the remote control will allow you to exit from the menus.

Use the Yellow Labeled Buttons for PIP Operations.

TV/VTR + CH - CH	Press to change the TV channel (+ to increase the channel number and - to decrease). For models KV 27S26 27V26 29RS26 29V66M 32S26 32V26 34RS26 35S26 and 37RS26 if you are watching the video input in the window picture, you must press VTR (FUNCTION) then use the main CH +/- buttons to change channels.
POSITION	Press to move the location of the window picture (counterclockwise) around the main picture.
FREEZE	Press to freeze the window picture. Great for copying down phone numbers, addresses, recipes, etc. If a window picture is displayed, then it will be frozen. If only the main picture is displayed, then it will be frozen and displayed as a window picture. Press FREEZE again to restore the previous screen(s).
SWAP	Press to switch the audio and video of the main picture and the window picture. Each time you press SWAP, the picture and sound of the two will be SWAPPED. The channels being received through the AUX jack cannot be displayed as a window picture (KV-27S36 27V36 29V36C 29V76M 32S36 32V36 34V36C 35S36 35V36 37RS26 37V36M only).

Adjusting your SET UP (menus) (continued)

Using the AUDIO menu

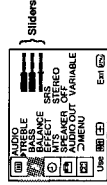

For detailed information on using the remote to modify menu settings, refer to Learning menu selection on page 18.

To select the AUDIO menu

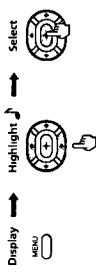

To restore the factory settings
Press RESET on the remote control while the AUDIO menu is displayed.

Tip
Press (for direct selection of an EFFECT setting).

Using the VIDEO menu



For detailed information on using the remote to modify menu settings, refer to Learning menu selection on page 18.

To select the VIDEO menu



To restore the factory settings
Press RESET on the remote control while the VIDEO menu is displayed.

TREBLE Sound Adjustment	Adjust slider right (cursor up) to increase higher pitched sounds. Adjust slider left (cursor down) to decrease higher pitched sounds.
BASS Sound Adjustment	Adjust slider left (cursor up) to decrease low pitched sounds. Adjust slider right (cursor down) to increase low pitched sounds.
BALANCE Sound Adjustment	Adjust slider left (cursor up) to emphasize left speaker volume. Adjust slider right (cursor down) to emphasize right speaker volume.
EFFECT Customize sound effect based on the program's audio type	SURROUND Simulates theater quality sound (only for stereo programs) (KV 27S26 27V36 29RS26 29RS26C 32S26 32V26 34RS26C 35S26 35S36 37RS26 only) SRS Produces a dynamic three dimensional sound for stereo or encoded audio (KV 27S26 27V36 34V36C 35V36 37V36M 37V36M 29V66M 29V76M 32V26 32V36 34V36C 35V36 37V36M 37V36M 29V66M 29V76M 32V26 32V36 34V36C 35V36 37V36M only) SIMULATED Adds a surround-like effect to mono programs (KV 27V26 27V36 29V36C 29V66M 29V76M 32V26 32V36 34V36C 35V36 35V76 37V36M only)
MTS Enjoy stereo bilingual and mono programs	STEREO Select for stereo reception when viewing a program broadcast in stereo. SAP Select to listen to bilingual broadcast (non-SAP programs will be muted). MONO Select for mono reception. (Use to reduce noise during stereo broadcasts). Outlet MTS access. Press MTS on your remote to cycle through the MTS options as follows: (STEREO → SAP → MONO → STEREO)
SPEAKER Custom selection of audio output source	ON Select to listen to the sound from the TV speakers and a separate stereo system external audio system speakers. OFF Select to turn off the TV speakers and listen to the TV's sound only through external audio system speakers.
AUDIO OUT Easy control of volume adjustments	AUDIO OUT can only be set when speakers are set to OFF. VARIABLE Sound output varies according to the TV settings. Volume, Bass, Treble and Balance are adjusted through the TV. Useful when you want to use your remote to control the output of a separate audio system. FIXED Sound output is held at a fixed level. Volume, Bass, Treble and Balance are fixed to the factory settings. Volume adjustments are made through your stereo.

Adjusting your SET UP (menus) (continued)

Using the SET UP menu

For detailed information on using the remote to modify menu settings, refer to Learning menu selection on page 18.

To select the SET UP menu

- Display →
- Highlight →
- Select →

If any menu items are grayed out, press the ANT button on your remote so that a channel number appears. Favorite channel feature is not available for the AUX input.

Using the TIMER menu

After setting the clock, you can use the timer to turn the TV on and off.

For detailed information on using the remote to modify menu settings, refer to Learning menu selection on page 18.

To select the TIMER menu

- Display →
- Highlight →
- Select →

Tip
Set daylight saving time before setting the clock. Any loss of power will cause these settings to be erased.

DAYLIGHT SAVING
Automatically adjusts the time.

CURRENT TIME SET
Necessary for the TIMER.

ON/OFF TIMER
Wake up or scheduled viewing.

Spring Select YES to compensate for Daylight Saving Time. The current time automatically moves one hour ahead.

Fall Select NO at the end of Daylight Saving Time. The current time moves back one hour.

CURRENT TIME SET window will appear

- Press * or # on the select buttons until the current day (MON-SUN) is displayed. Press (←) to select.
- Press * or # on the select buttons until the current hour (01-12) and AM/PM is displayed. Press (←) to select.
- Press * or # on the select buttons until the current minute (00-59) is displayed.
- Press (←).

The Clock has now started. Press MENU to exit.

ON/OFF TIMER window will appear

- Press * or # on the select buttons until the desired day (MON-SUN) or range of days (EVERY Sun-Sat or EVERY Mon-Fri) is displayed. Press (←) to select.
- Indicate the time (hours then minutes) that you want the TV to turn on by pressing * or # and then (←).
- Set the time duration (maximum of 6 hours) by pressing * or # and then (←).

TO CANCEL THE TIMER FUNCTION, PRESS RESET

- Press * or # on the select buttons to select the desired channel. Press (←) to select.

The timer is now set. The TIMER indicator on your TV will be lit. Press MENU to exit. When you perform AUTO PROGRAM, all TIMER settings will be erased.

CHANNEL SET UP window open

- Use * or # to select the feature you want to change.
- Press (←) to access the feature.

CABLE Select ON if your TV is connected to a cable system. (AUTO SET UP will set CABLE to ON automatically when it programs the TV.)

CHANNEL FIX Use this feature to set the TV's input to one of the following options.

- 2-6 Choose when the cable box is connected to the VHF/UHF input and you do not want to switch to AUX mode. Once this setting is made, you will not be able to use the TV function CH+/- to change channels. Instead, use the "Cable function" CH +/-.
- AUX 2-6 Choose when a cable box is connected to AUX and a cable or antenna is connected to ANT. You can alternate between the two inputs by pressing ANT on the remote control (KV-27S36 27V36, 29V36C 29V76M, 32S36 32V36, 34V96C 34S36, 35V76 35V76M 37V36M only).

VIDEO 1 Choose when you have connected video equipment (e.g. AV receiver) and you want TV input fixed to it. You will only be able to switch between video sources.

TIMER and CHANNEL BLOCK settings are erased when CHANNEL FIX is set

AUTO PROGRAM Instructs the TV to automatically program all receivable channels.

CHANNEL ERASE/ADD With the CHANNEL ERASE/ADD window open

- Place the cursor next to ERASE or ADD.
- Select the desired channel using CH+/- or by selecting with the 0-9 buttons and pressing ENTER.
- Press (←) to activate.

CHANNEL CAPTION With the CHANNEL CAPTION window open

- Press (←) and then * or # on the select buttons to select the desired channel, and press (←) again.
- Press * or # on the select buttons to display the first letter or number of the caption and press (←) to select it. (Repeat until all four digits are selected).
- Press (←) to activate. To erase a Caption, press RESET.

MDP manufacturer numbers	Manufacturer	Code
341 312 309	Singer	315
314 336 337	Samsung	322 313 321
319 320 317 318 341	Sanyo	330 335
330 334 335 333	Sharp	312 313 321 335 323 324 325 326
329 304 309	Shimizu	327 328
306 304 305 332	Signature 2000 (M Wards)	315
309 305 304	Sylvania	308 309 338 310
309 305 304	Symphonie	338
314 336 337	Toshiba	314 336 337
314 336 337	Toshiba	314 336 338 309 308
314 336 337	Technics	309 308
332 305 333 334 330 335 338	Toshiba	312 311
306 309 310	Wards	327 328 335 331 332
314 336 337	XR-1000	315
309 335	Yamaha	330 314 336 337
309 335	Zenith	331

Operating video equipment

Setting the manufacturer's code

You can use the supplied remote control to operate Sony or non-Sony video equipment that has an infrared sensor.

- Press CODE SET.
- Press VTR (FUNCTION).
- Use the 0-9 buttons to key in the manufacturer's code number from the following chart.
- Press ENTER.

VCR manufacturer numbers	Manufacturer	Code
301 302 303	Sony	301 302 303
338 344	Amira	338 344
314 337	Admiral (M Wards)	314 337
330 343	Audio Dynamic	330 343
309 309	Beit & Howell (M Wards)	309 309
309 309	Beit & Howell (M Wards)	309 309
309 309	Beit & Howell (M Wards)	309 309
315 302 332	Clizen	315 302 332
315 302 315	Clizen	315 302 315
304 338 309	Curtis Mathis	304 338 309

CHANNEL BLOCK

You will be able to block two channels. With the CHANNEL BLOCK window open

- Select 1 or 2 and the select buttons (←) to select the channel you want to block.
- Press (←) to activate.

When you select the blocked channel, 'BLOCKED' will appear on the screen. Caption Vision XDS and output from the selected channel will also be blocked. To erase your CHANNEL BLOCK settings, press RESET while in the CHANNEL BLOCK window. When you perform AUTO PROGRAM, your CHANNEL BLOCK settings will be erased.

Setting FAVORITE CHANNEL

With the FAVORITE CHANNEL window open

- Press (←) to select the channel you want to watch, and press (←) again.
- Press (←) to select the channel you want to watch, and press (←) again.
- Press * or # on the select buttons to select the desired channel and press (←).
- For KV-27S36 27V36, 29V36C 29V76M, 32S36 32V36, 34V96C 34S36, 35V76 37V36M only, you can preview your favorite channels in the window picture to do so. See PREVIEW DISPLAY to ON.

Using FAVORITE CHANNEL

- Press (←) and your FAVORITE CHANNEL options appear.
- Press * or # to select the channel you want to watch, and press (←).
- For models KV-27S36 27V36, 29V36C 29V76M, 32S36 32V36, 34V96C 34S36, 35V76 37V36M only, if PREVIEW is turned on, when a window picture will display your favorite channels as you cycle through the options you can label VIDEO 1 IN as VHS).

This feature allows you to label each input mode so that you can easily identify the connected equipment (e.g. you can label VIDEO 1 IN as VHS).

- Press * or # on the select buttons to select the input mode you want to label and press (←).
- Press * or # to select the label and press (←).

VIDEO LABEL Options

Video 1 VHS 8mm BETA LD GAME DBS DVD WEB RECEIVER
Video 2 VHS 8mm BETA LD GAME DBS DVD WEB

(Except Canadian models)
Select from available languages to cause all menus to appear in your language of choice.

TILT CORRECTION
Adjust your picture

Use this feature to correct any tilt of the picture KV 35S26 35S36 35V76 37RS26 37V36M only. Press * or # on the select buttons to select a correction between +5 and -5 and press (←).

Operating a cable box or DBS receiver

Programming the remote

You can program the supplied remote control to operate a cable box or DBS receiver.

- 1 Press CODE SET
- 2 Press DBS/CABLE (FUNCTION)
- 3 Use the 0-9 buttons to key in the manufacturer's code number from the following chart
- 4 Press ENTER

To operate the TV

Press TV (FUNCTION). Then use the TV control buttons to control the TV.

For more details on operating the cable box or DBS receiver

Refer to the operating instructions that come with the equipment.

Buttons on the remote control

To turn on or off	Press VTR (POWER)
To play	Press the
To stop	Press
To pause	Press
To resume normal playback	Press again
To search the picture forward or backward	Keep pressing or during playback
To resume normal playback	release the button
To search the chapter forward or backward	Press CH +/-

Buttons on the remote control

To turn on or off	Press VTR (POWER)
To select a channel directly	Press the 0 - 9 buttons
To change channels	Press CH +/-
To record	Press while pressing then release
To play	Press
To stop	Press
To fast forward	Press
To rewind the tape	Press
To pause	Press
To resume normal playback	press again
To search the picture forward or backward	Press or during playback
To resume normal playback	release the button
To change input mode	Press TV/VTR

- 702 Pioneer
706 RCA
705 Sharp
703 Yamaha

Tips

- In some cases, you may not be able to operate your Sony video equipment with the supplied remote control. In these cases, please use the equipment's own remote control.
- The code numbers for Sony equipment are assigned at the factory as follows.

- VHS VCR 301 (preset code for the supplied remote control)
302
8 mm VCR 302
Beta, ED Beta VCRs 303
- When you remove the batteries, the code number may revert to the factory setting.

Manufacturer	Code number
Hamlin/Regal	222 223 224 225 226
Jerrild/G I	207 202 203 204 205 206
Panasonic	207 208 218
Oak	227 228 229
Pioneer	219 220 221
Scientific Atlanta	214 215
Toocom	209 210 211
Zenith	216 217
	212 213

If the remote control doesn't work

- First try repeating the setup procedures using the other codes listed for your equipment.

Tips

- If more than one code number is listed, try entering them one by one until you come to the correct code for your equipment.
- If you enter a new code number, the code number you previously entered at the setup is erased.
- In some cases, you may not be able to operate your equipment with the supplied remote control. In these cases, use the equipment's own remote control.
- Whenever you remove the batteries — to replace them, for example — if too much time is taken the code numbers may revert to the factory setting and must be reset.

Manufacturer code numbers (cable box)

Manufacturer	Code number
Hamlin/Regal	222 223 224 225 226
Jerrild/G I	207 202 203 204 205 206
Panasonic	207 208 218
Oak	227 228 229
Pioneer	219 220 221
Scientific Atlanta	214 215
Toocom	209 210 211
Zenith	216 217
	212 213

Manufacturer code numbers (DBS receiver)

Manufacturer	Code number
Sony	801 (preset code for remote control)
General Electric	802
RCA/PROSCAN	802

Troubleshooting

Troubleshooting

Cannot Operate Single Tuner PIP (KV 27S26, 27V26, 29PS26, 29RS26, 30V68M, 32S26, 32V26, 34RS26C, 35S26, 37RS26 only)

Check that cable is connected to the VCR and the VCR is turned on.

Check that the VCR is connected to the TV.

No picture (screen not lit), no sound

Make sure the power cord is plugged in.

Operate with the buttons on the TV and the remote control.

Insert the batteries in the remote control with the correct polarity.

Replace the batteries with new ones if they are weak.

Check to see if the TV/VIDEO setting is correct when watching TV, set to TV and when watching video tapes set to VIDEO1 or 3.

Try another channel. It could be station trouble.

Perform AUTO SET UP again using the SET UP button to return to the factory preset condition. (page 13)

Good picture, no sound

Press MUTING so that "MUTING" disappears from the screen. (page 14)

Check the MTS setting in the AUDIO menu. (page 20)

Make sure SPEAKER is set to ON in the AUDIO menu. (page 20)

Perform AUTO SET UP again using the SET UP button to return to the factory preset condition. (page 13)

No color

Adjust the COLOR in the VIDEO menu (page 19)

Poor or no picture (screen lit), good sound

Adjust PICTURE in the VIDEO menu (page 19)

Adjust BRIGHTNESS in the VIDEO menu (page 19)

Check antenna/cable connections

Perform AUTO SET UP again using the SET UP button to return to the factory preset condition. (page 13)

Remove objects from the front of TV

Check the LIGHT SENSOR setting in the VIDEO menu. (page 19)

Black and white programs cannot be seen in color

Perform AUTO SET UP again using the SET UP button to return to the factory preset condition. (page 13)

Only snow and noise appear on the screen

Check the CABLE setting in the SET UP menu. (page 22)

Check the antenna/cable connections

Make sure the channel is broadcasting programs

Press ANT to change the input mode (page 15)

Dotted lines or stripes

Adjust the antenna

Move the TV away from noise sources such as cars, neon signs or hair-dryers

Double images or ghosts

Use a highly directional outdoor antenna or a cable (when the problem is caused by reflections from nearby mountains or tall buildings)

Cannot operate menu

If the item you want to choose appears in grey, you cannot select it. Press TV/VIDEO correctly.

Troubleshooting (continued)

Cannot receive upper channels (UHF) when using an antenna

Make sure CABLE is OFF in the SET UP menu. (page 22)

Use AUTO PROGRAM to add receivable channels that are not presently in TV memory. (page 22)

Cannot receive any channels when using cable TV

Make sure CABLE is ON in the SET UP menu. (page 22)

Use AUTO PROGRAM to add receivable channels that are not presently in TV memory. (page 22)

Remote control does not operate

Batteries could be weak. Replace the Press TV (FUNCTION) when operating your TV.

Make sure the TV's power cord is connected securely to the wall outlet fluorescent lights

Check the S-Link connection. (page 4 5)

TV malfunctions when using the S-Link function (KV 27V26, 27V36, 29V36C, 29V68M, 32V26, 32V36, 34V36C, 35V36, 35V76 37V36M only)

Make sure the TV's power cord is connected securely to the wall outlet

Check the S-Link connection. (page 4 5)

SECTION 2 DISASSEMBLY

2-1. REAR COVER REMOVAL

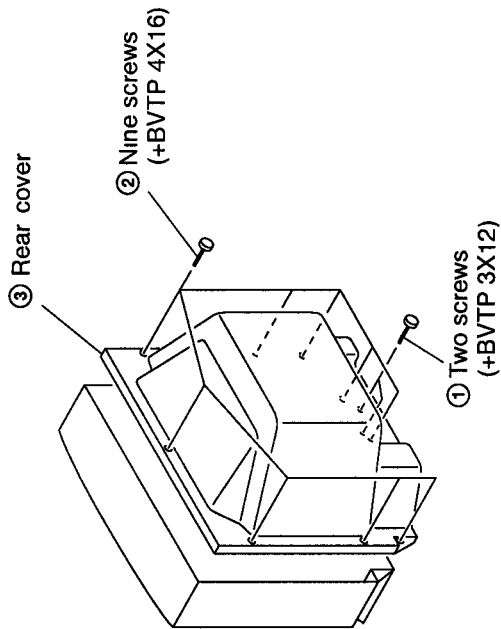

2-3. SERVICE POSITION

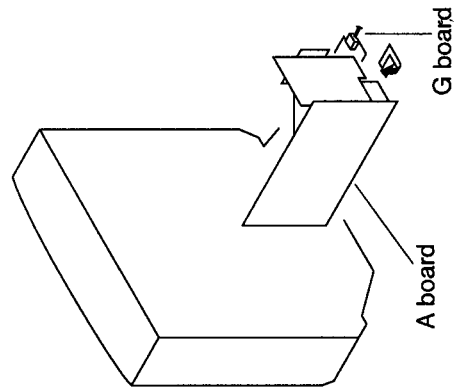

2-2. CHASSIS ASSY REMOVAL

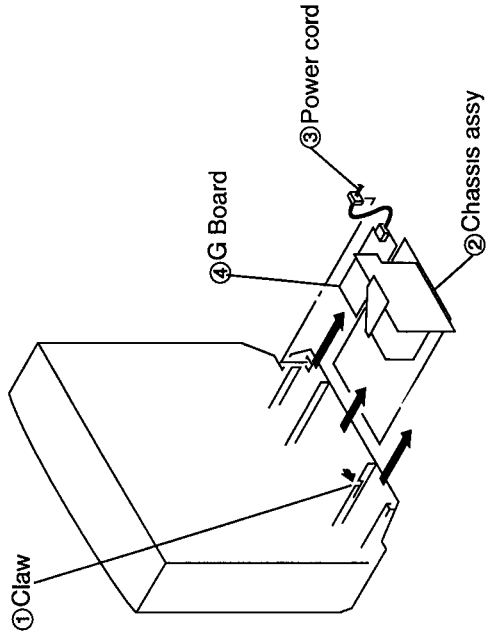

2-4. PICTURE TUBE REMOVAL

WARNING : Before removing anode cap HV remains in the CRT even after the power is disconnected

To avoid electrical shock before attempting to remove the anode cap, discharge CRT Short between anode and CRT coated earth ground strap

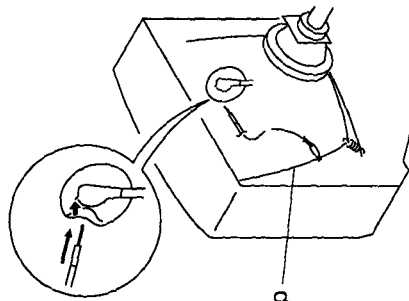

Coated earth ground strap

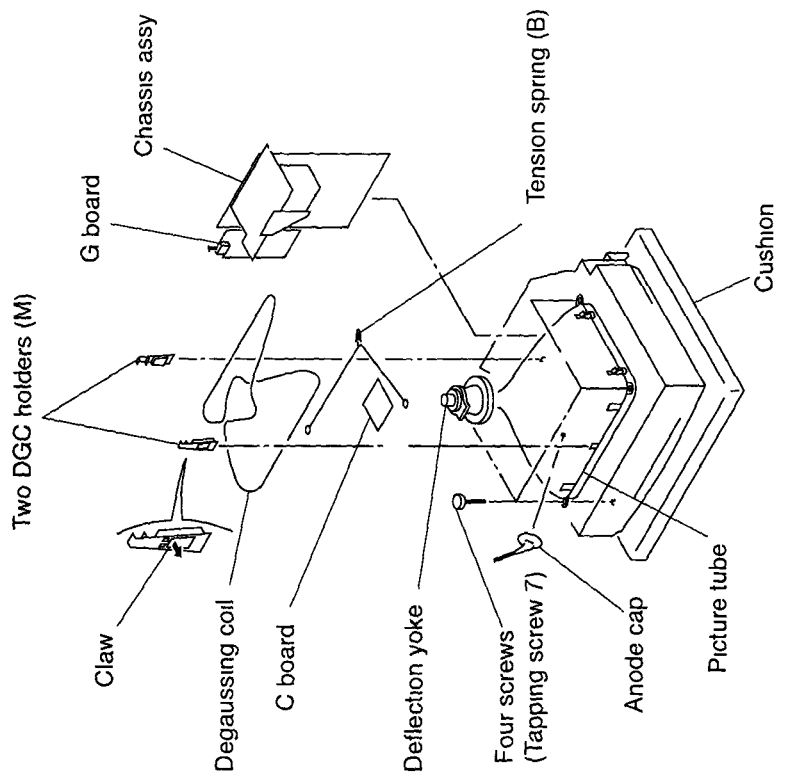

• REMOVAL OF THE ANODE-CAP

NOTE After removing the anode, short circuit the anode of the picture tube and the anode cap to the metal chassis, CRT shield or carbon painted on the CRT

• REMOVAL PROCEDURES • HOW TO HANDLE AN ANODE-CAP

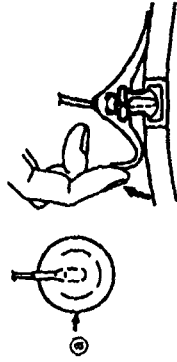

① Turn up one side of the rubber cap in the direction indicated by arrow (a)

Do not use sharp objects which may cause damage to the surface of the anode-cap

Do not squeeze the rubber covering too hard to avoid damaging the anode-cap. A material fitting called a shatter-hook terminal is built into the rubber

Do not force turn the foot of the rubber cover. This may cause the shatter-hook terminal to protrude and damage the rubber

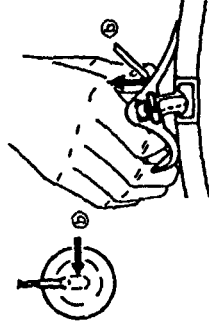

② Use your thumb to pull the rubber cap firmly in the direction indicated by arrow (b)

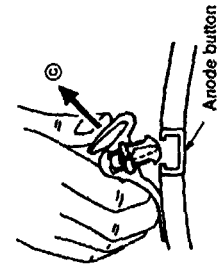
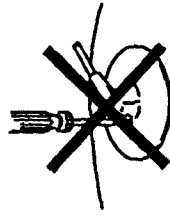

③ When one side of the rubber cap separates from the anode button, the anode-cap can be removed by turning the rubber cap and pulling it in the direction of arrow (c)

**SECTION 3
SAFETY RELATED ADJUSTMENTS**

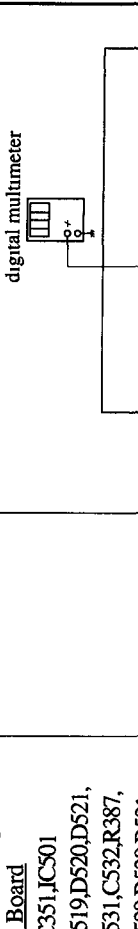
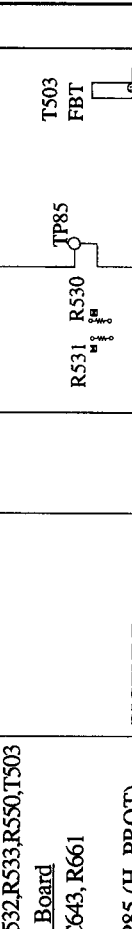
ADJUSTMENT ITEM AND PROCEDURE	EQUIPMENT AND SIGNAL	MEASUREMENT POSITION	ADJUSTMENT LOCATION	ILLUSTRATION AND SHAPE AND NUMBER
<p>RESISTOR CONFIRMATION METHOD (HOLD-DOWN CONFIRMATION) AND READJUSTMENTS</p> <p>The following adjustments should always be performed when replacing the components marked with <input checked="" type="checkbox"/> on the A and G Board schematic diagrams (Hold-down operation confirmation)</p> <p>Step 1 Preparation before confirmation a) Turn the POWER switch ON, input a white signal and set the PICTURE and BRIGHTNESS controls to maximum</p> <p>b) Confirm that the voltage at the check terminal of TP85 is more than 18 0 VDC when the set is operating normally (120 ± 2 0 VAC) or (220 ± 2 0 VAC for KV-29RS22C/29RS26C)</p> <p>Step 2 Input a white signal and verify that I ABL is within the specified range</p> <p>Step 3 Record the voltage between TP85 and ground</p> <p>Step 4 Using an external DC power supply, apply voltage between TP 85 and ground Increase the voltage gradually and confirm that the hold-down works (raster disappears) at lower than the voltage recorded in Step 3</p> <p>Step 5 Confirm that a voltage of more than 18 0 VDC appears between TP85 and ground</p>	<p>White Picture</p> <p>Digital multimeter</p> <p>White Picture</p> <p>White Picture</p>	<p><input checked="" type="checkbox"/> marked parts A Board IC351, IC501 D519, D520, D521, C531, C532, R387, R529, R530, R531 R532, R533, R550, T503 G Board IC643, R661</p> <p>TP85 (H PROT)</p>	<p><input checked="" type="checkbox"/> R530, 531</p> <p>PICTURE BRIGHTNESS maximum</p>  <p>PICTURE BRIGHTNESS maximum</p> 	<p>A BOARD - CONDUCTOR SIDE -</p> <p>[Check Condition] Step 2 2160 ± 100 µA 120 ^{+2.0} VAC (Power Supply) 220 ^{+2.0} VAC (Power Supply) (KV-29RS22C/ 29RS26C)</p> <p>[Check Condition] Step 4 lower than 22 05 V DC 120 ^{+2.0} VAC (Power Supply) 220 ^{+2.0} VAC (Power Supply) (KV-29RS22C/ 29RS26C)</p> <p>[Check Condition] Step 5 more than 18 0V DC 120 ^{+2.0} VAC (Power Supply) 220 ^{+2.0} VAC (Power Supply) (KV-29RS22C/ 29RS26C)</p>

SECTION 4 DIAGRAMS

4-2. CIRCUIT BOARDS LOCATION

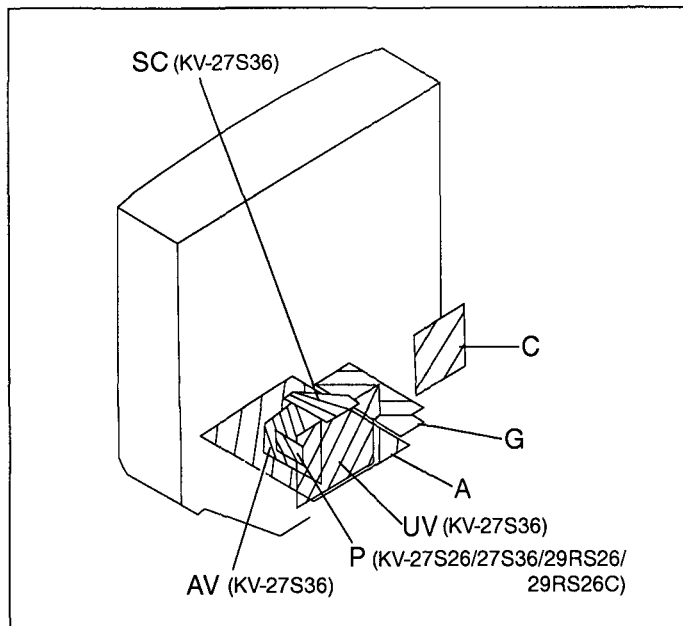

4-3. PRINTED WIRING BOARDS AND SCHEMATIC DIAGRAMS

Note

- All capacitors are in μF unless otherwise noted pF $\mu\mu\text{F}$ 50WV or less are not indicated except for electrolytics and tantalums
- All electrolytics are in 50V unless otherwise specified
- All resistors are in ohms
k Ω =1000 Ω , M Ω =1000k Ω
- Indication of resistance, which does not have one for rating electrical power, is as follows

Pitch 5mm
Rating electrical power 1/4 W

- 1/4 W in resistance, 1/10 W and 1/8 W in chip resistance
- nonflammable resistor
- fusible resistor
- Δ internal component
- panel designation and adjustment for repair
- All variable and adjustable resistors have characteristic curve B, unless otherwise noted
- The components identified by in this basic schematic diagram have been carefully factory-selected for each set in order to satisfy regulations regarding X-ray radiation
Should replacement be required, replace only with the value originally used
- When replacing components identified by , make the necessary adjustments indicated. If results do not meet the specified value, change the component identified by and repeat the adjustment until the specified value is achieved
(Refer to R530 and R531 adjustment on Page 14 – 15)
- When replacing the part in below table, be sure to perform the related adjustment

Part replaced()	Adjustment()
IC351, IC501, D519, D520, D521	R530, R531
C531, C532, R387, R529, R530, R531, R532, R333, R550, T503	A BOARD
IC643, R661	G BOARD

Reference information

RESISTOR	RN	METAL FILM
	RC	SOLID
	FPRD	NONFLAMMABLE CARBON
	FUSE	NONFLAMMABLE FUSIBLE
	RW	NONFLAMMABLE WIREWOUND
	RS	NONFLAMMABLE METAL OXIDE
	RB	NONFLAMMABLE CEMENT
	X	ADJUSTMENT RESISTOR
COIL	LF-8L	MICRO INDUCTOR
CAPACITOR	TA	TANTALUM
	PS	STYROL
	PP	POLYPROPYLENE
	PT	MYLAR
	MPS	METALIZED POLYESTER
	MPP	METALIZED POLYPROPYLENE
	ALB	BIPOLAR
	ALT	HIGH TEMPERATURE
	ALR	HIGH RIPPLE

Note

The symbol display is on the component side

The components identified by shading and mark Δ are critical for safety. Replace only with part number specified

The symbol indicate fast operating fuse. Replace only with fuse of same rating as marked

Note

Les composants identifiés par un trame et une marque Δ sont critiques pour la sécurité. Ne les remplacer que par une pièce portant le numéro spécifié

Le symbole indique une fusible à action rapide. Doit être remplacée par une fusible de même valeur, comme marqué

P BOARD IC VOLTAGE LIST

IC3301		21	3.0	12	0.3
pin	volt	22	4.7	13	NC
1	GND	23	GND	14	-3.0
2	NC	24	2.9	15	GND
3	GND	IC3302		16	GND
4	4.0	pin	volt	17	0.7
5	6.8	IN	9.1	18	0.5
6	GND	OUT	5.3	19	0.2
7	0.2	IC3303		20	0.3
8	0	pin	volt	21	5.1
9	1.8	1	GND	22	5.2
10	0.3	2	3.2	23	NC
11	8.2	3	2.6	24	NC
12	8.2	4	2.3	25	GND
13	3.9	5	5.1	26	NC
14	3.4	6	GND	27	GND
15	GND	7	0.5	28	2.3
16	2.8	8	0	29	5.2
17	NC	9	0.6	30	2.6
18	2.5	10	5.2	31	4.2
19	3.5	11	2.1	32	2.5
20	3.0				

All voltages are in V

P BOARD TRANSISTOR VOLTAGE LIST

	B	C	E
Q3301	5.3	9.1	4.7
Q3305	0.5	GND	1.2
Q3306	0.8	GND	1.4
Q3307	0.6	GND	1.3
Q3308	0	2.8	GND
Q3310	0	5.2	GND
Q3312	0	0	0.8
Q3313	0.8	0.4	GND

All voltages are in V

P [P in P]
(KV-27S26/27S36/29RS26/29RS26C)

<COMPONENT SIDE>

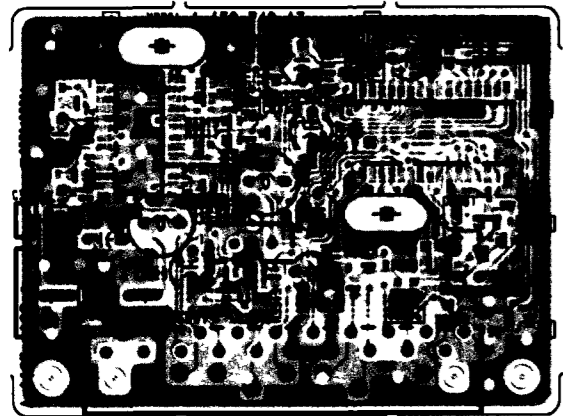

<CONDUCTOR SIDE>

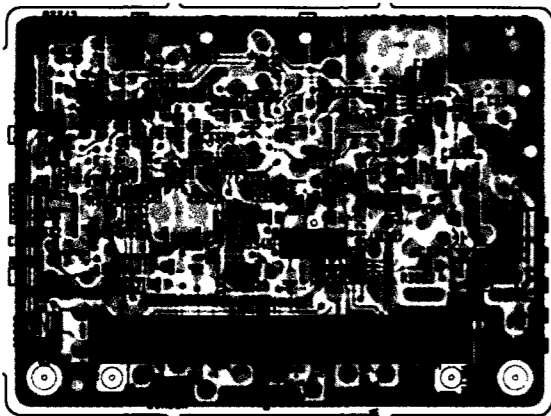

Pattern from the side which enables seeing
Pattern of the rear side

P BOARD WAVEFORMS

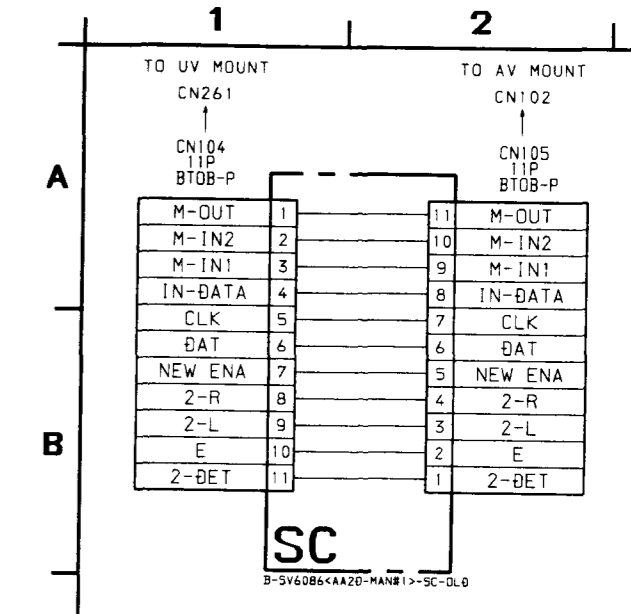
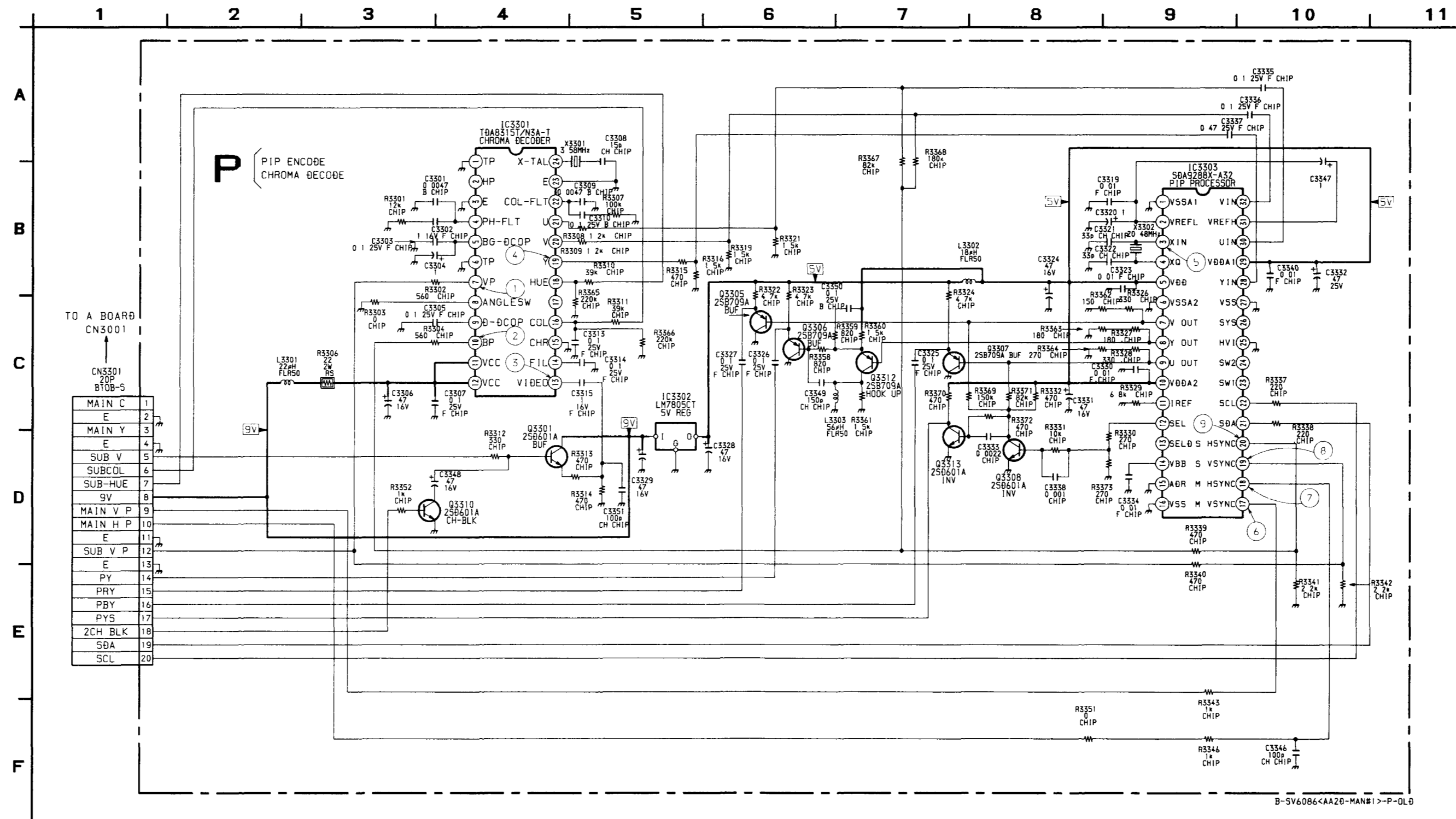
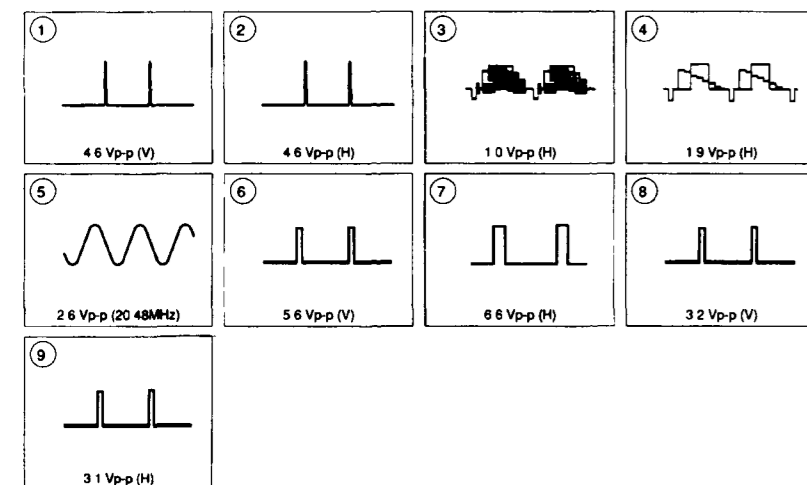

SC (KV-27S36 ONLY)

- SC BOARD -

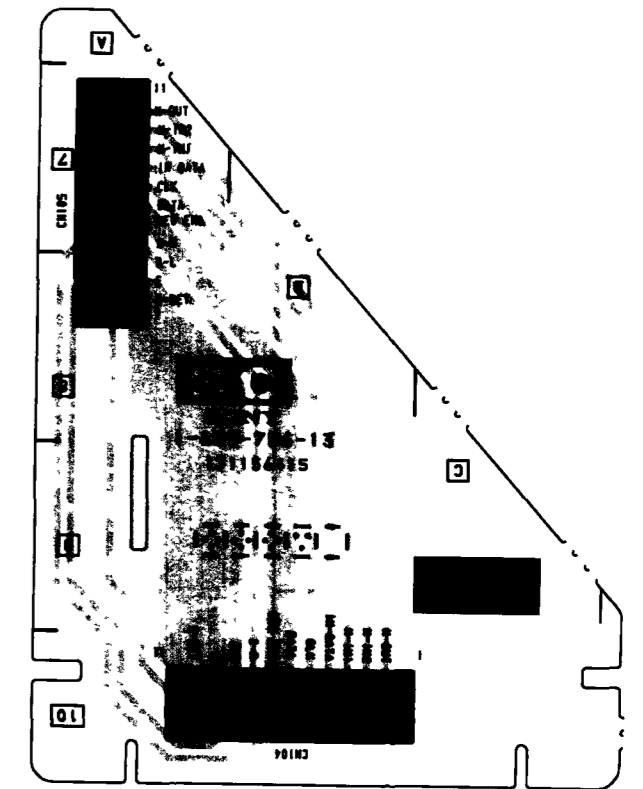

A [MICON, Y/C/J, TUNER, VOL-CTL, AUDIO-AMP, PIN-MOD, V DEF, H DEF, AV-SW]

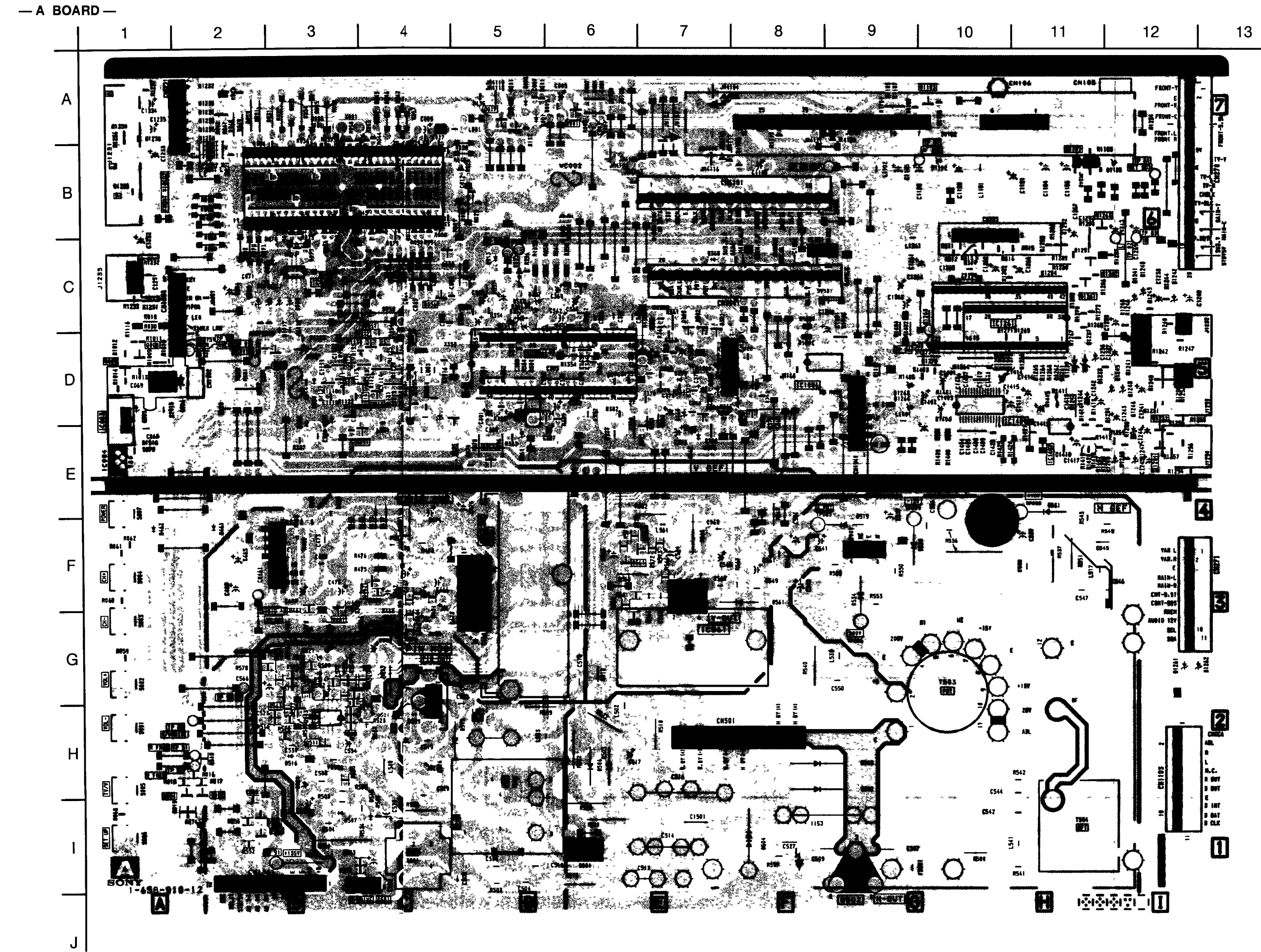

A BOARD LOCATOR LIST

DIODE	IC003	D-1
D001	A-5	D-5
D002	D-3	F-5
D003	A-5	F-5
D004	C-2	G-7
D005	D-1	H-8
D006	D-1	H-10
D011	A-5	E-11
D013	C-5	TRANSISTOR
D014	D-3	Q001 A-5
D015	C-4	Q002 C-4
D353	D-7	Q003 H-2
D356	E-3	Q004 H-1
D360	E-7	Q010 D-4
D362	E-7	Q011 D-4
D368	C-7	Q012 D-4
D462	F-1	Q013 D-4
D501	H-3	Q014 D-3
D502	H-9	Q015 D-3
D503	H-9	Q016 D-3
D504	I-8	Q017 A-5
D505	H-6	Q301 C-7
D506	H-6	Q302 C-7
D507	I-3	Q303 C-7
D515	H-5	Q354 D-7
D516	H-3	Q356 C-4
D518	I-4	Q357 E-5
D519	F-9	Q358 D-8
D520	G-3	Q481 G-3
D521	G-3	Q482 F-3
D530	F-9	Q501 J-4
D531	E-11	Q502 J-9
D534	F-9	Q511 H-3
D561	F-8	Q512 H-4
D562	G-3	D551 I-2
D1102	B-10	D552 I-2
D1103	B-12	Q561 F-6
D1247	E-12	Q562 F-6
D1248	E-12	Q563 H-2
D1261	G-12	Q1102 A-11
D1262	G-12	Q1103 A-10
D1263	D-9	Q1231 E-12
D1264	E-9	Q1232 E-12
IC		
IC001	B-4	Q1262 C-11
IC002	C-3	Q1263 B-11

A BOARD: IC1001 CXA1315M

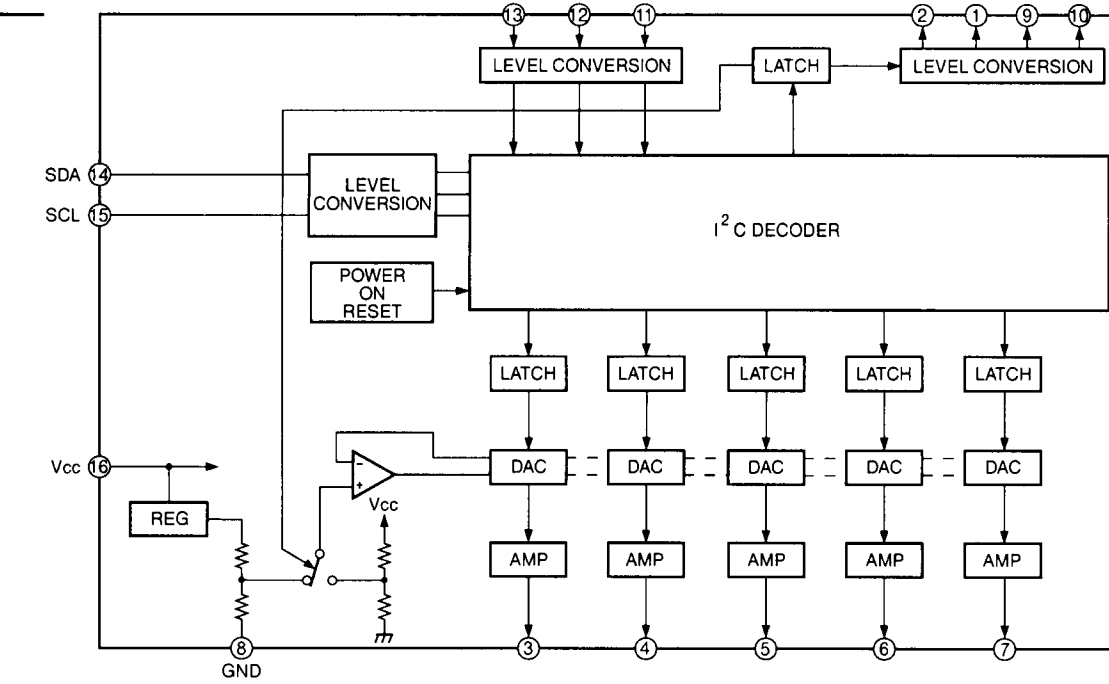

A BOARD IC1261 MM1313AD (KV-27S26/29RS26/29RS26C)

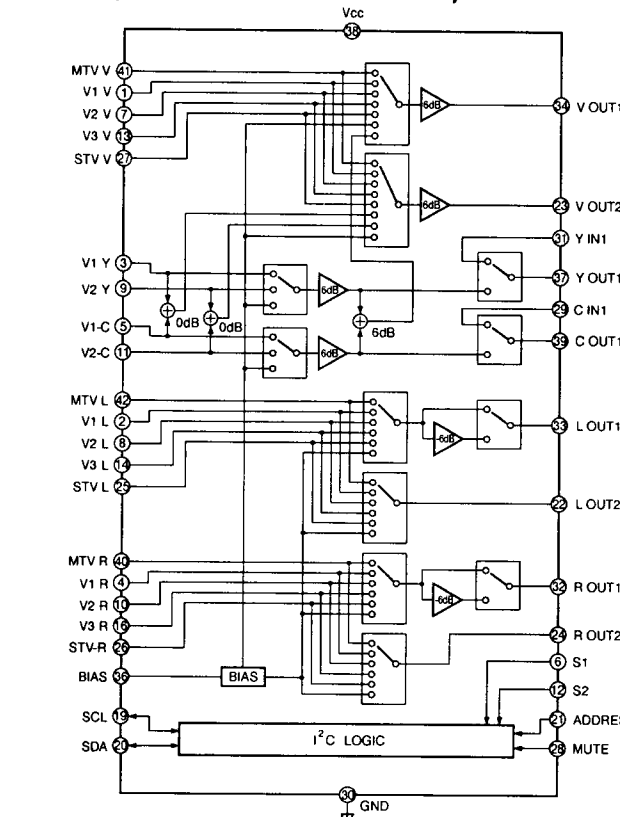

A BOARD IC1261 MM1311AD (KV-27S22/29RS22/29RS22C/29SD2/29PS2)

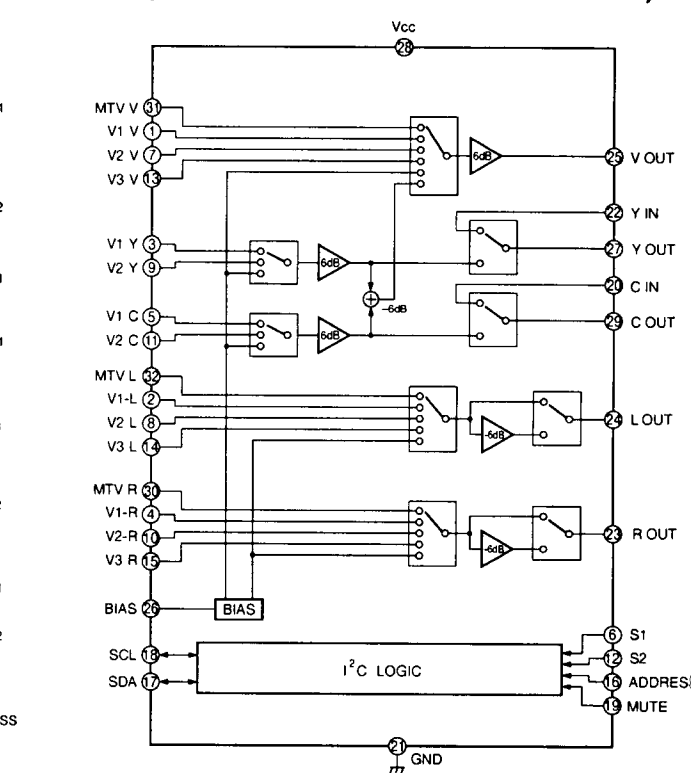

A BOARD: IC1401 BH3856FS

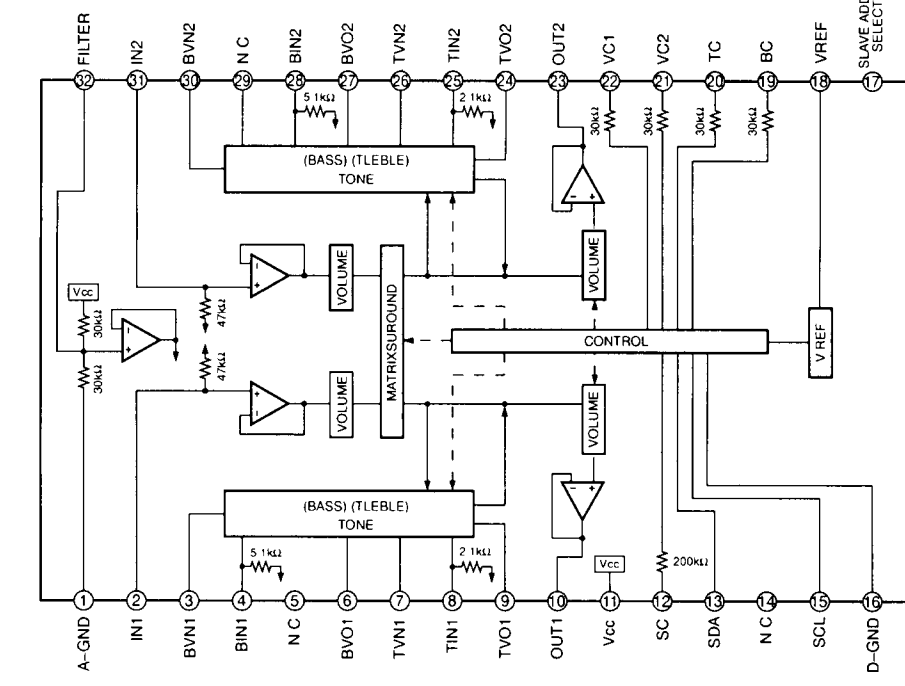

A BOARD: IC1402 NJM4558M

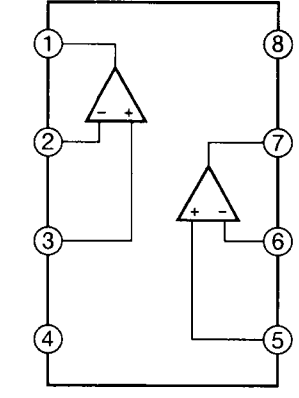

A BOARD: IC561 TDA 8172

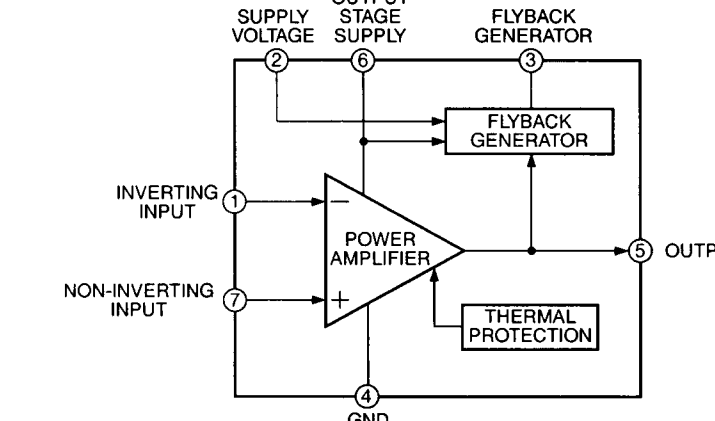

A BOARD: IC461 TDA2009A

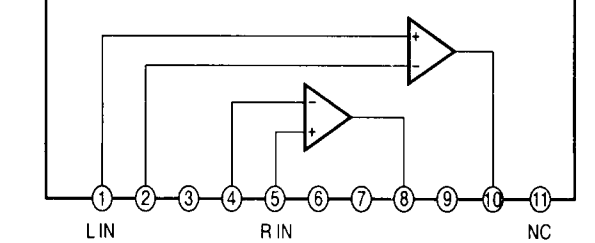

NOTE
Portions of the circuit marked as shown are high voltage areas. Use care to prevent electric shocks during inspection or repair.

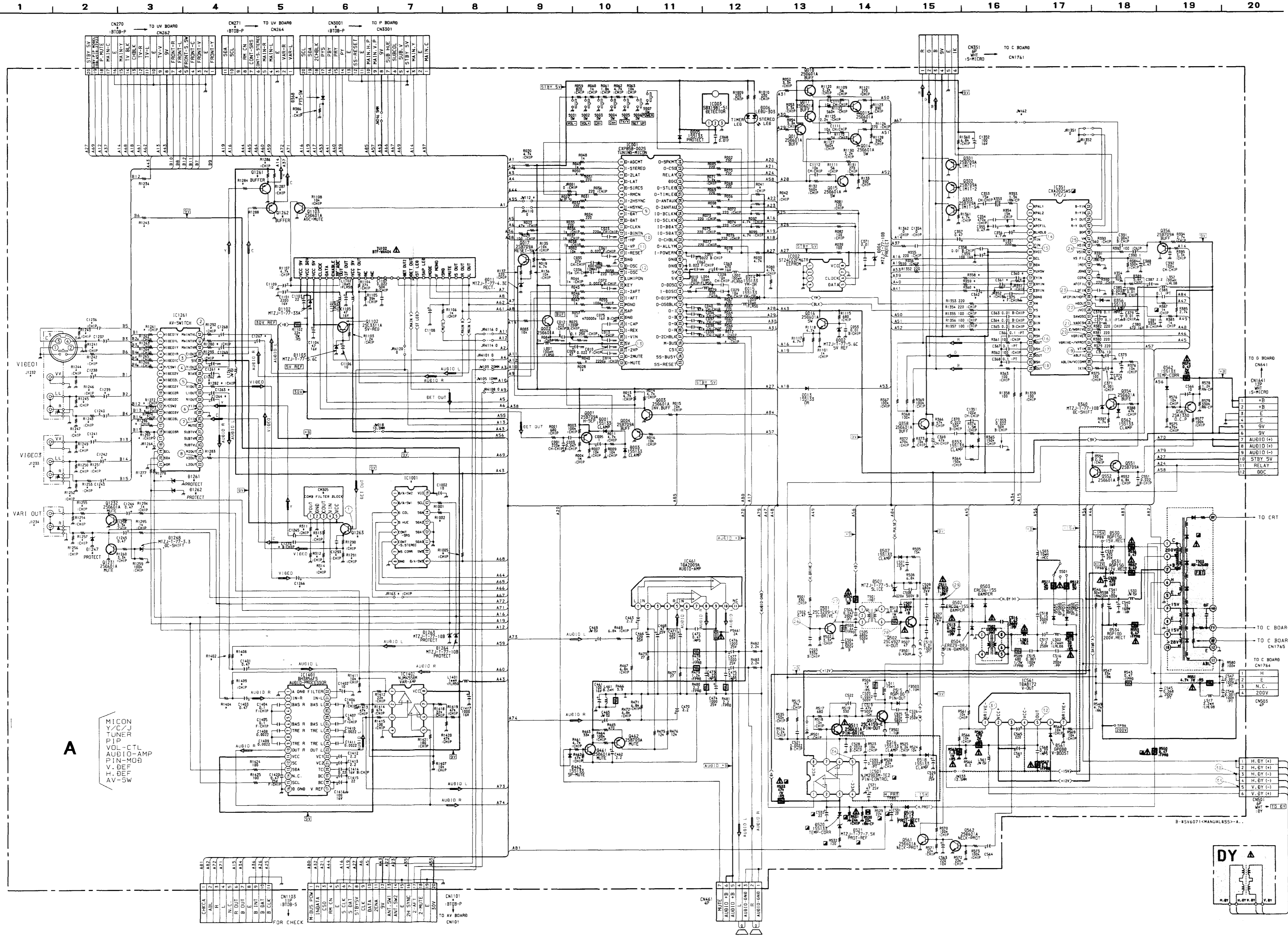

A BOARD (*) MARK LIST

Table listing components for A BOARD, including part numbers, descriptions, and quantities. Components include ICs like KV-27S22, KV-27S26, KV-27S36, and various resistors and capacitors.

A BOARD IC VOLTAGE LIST

Table listing IC voltages for A BOARD, showing pin numbers and voltage levels for various ICs like IC001, IC100, IC200, etc.

A BOARD TRANSISTOR VOLTAGE LIST

Table listing transistor voltages for A BOARD, showing transistor types and voltage levels for various transistors like Q001, Q002, Q003, etc.

A BOARD WAVEFORMS

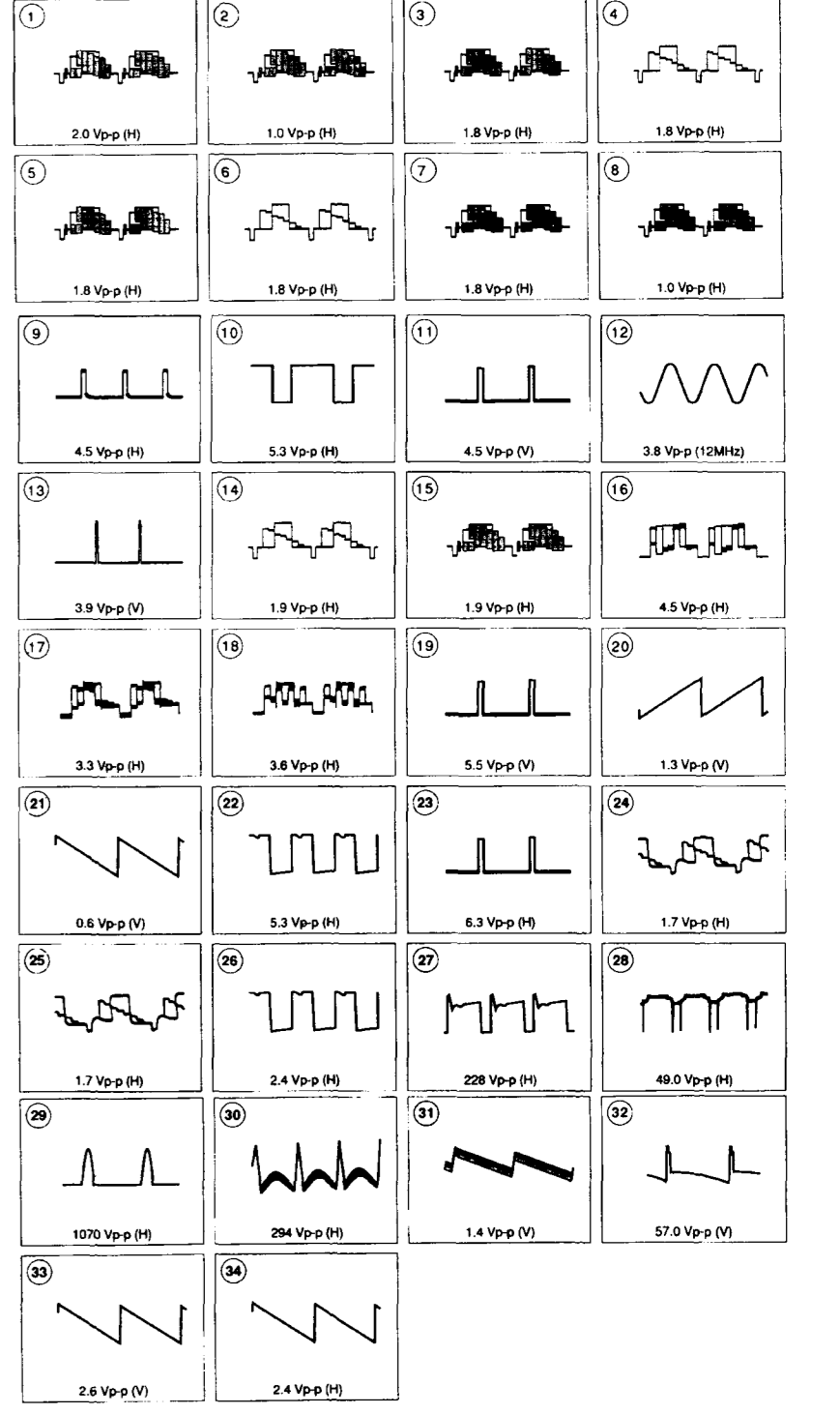

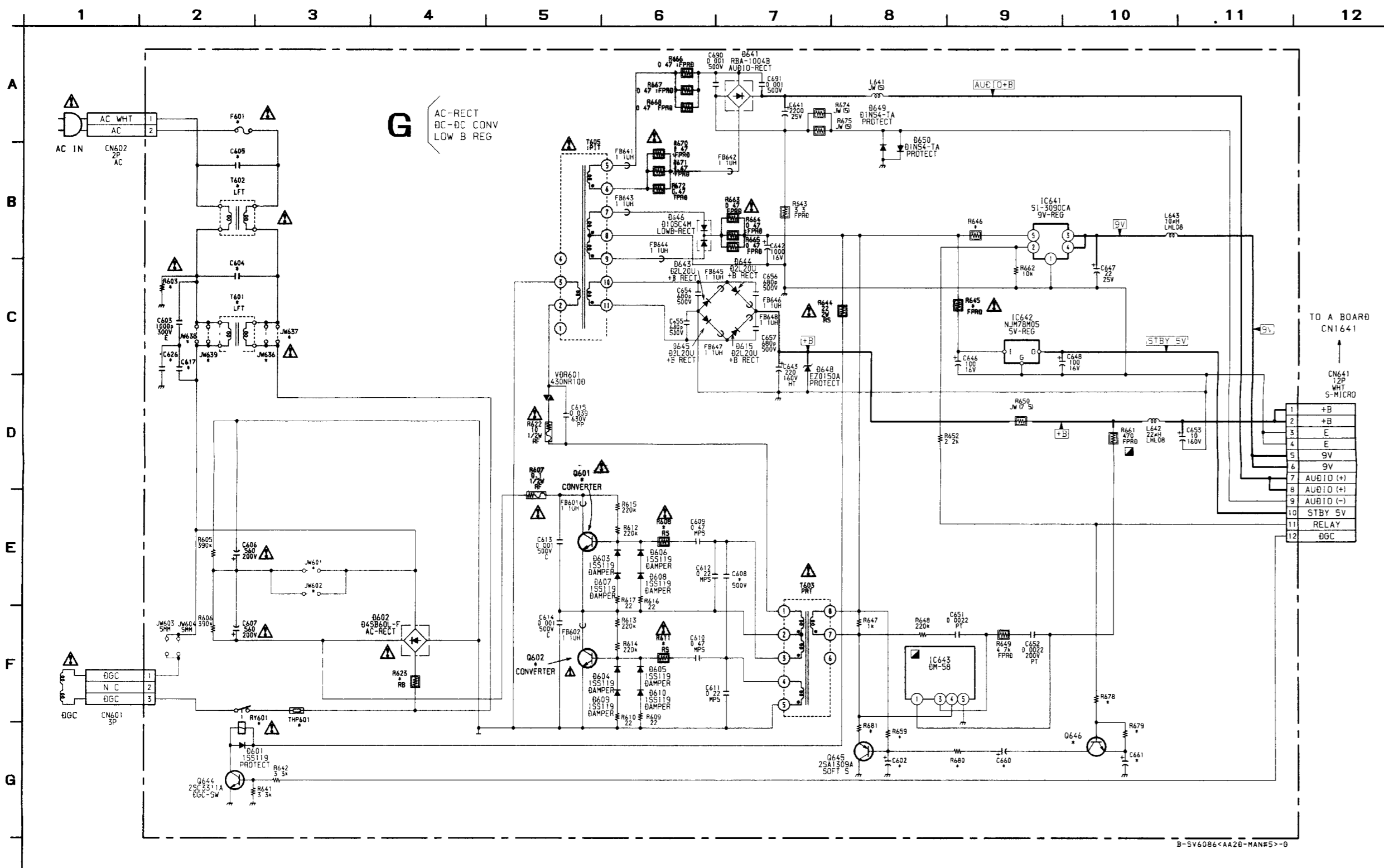

G BOARD IC VOLTAGE LIST

IC	pin	volt
IC641	1	GND
	2	3.9
	3	8.9
	4	8.9
	5	10.5
IC642	IN	5.0
IC643	1	13S
	2	NC
	3	2.5
	4	7.8
	5	GND

All voltages are in V

G BOARD TRANSISTOR VOLTAGE LIST

Q	B	C	E
Q601	145.2	294.0	147.5
Q602	-1.7	147.5	GND
Q644	-0.3	10.5	GND
Q645	7.0	GND	7.6
Q646	4.8	7.4	4.8

All voltages are in V

G [AC-RECT, DC-DC CONV, LOW B REG]

— G BOARD —

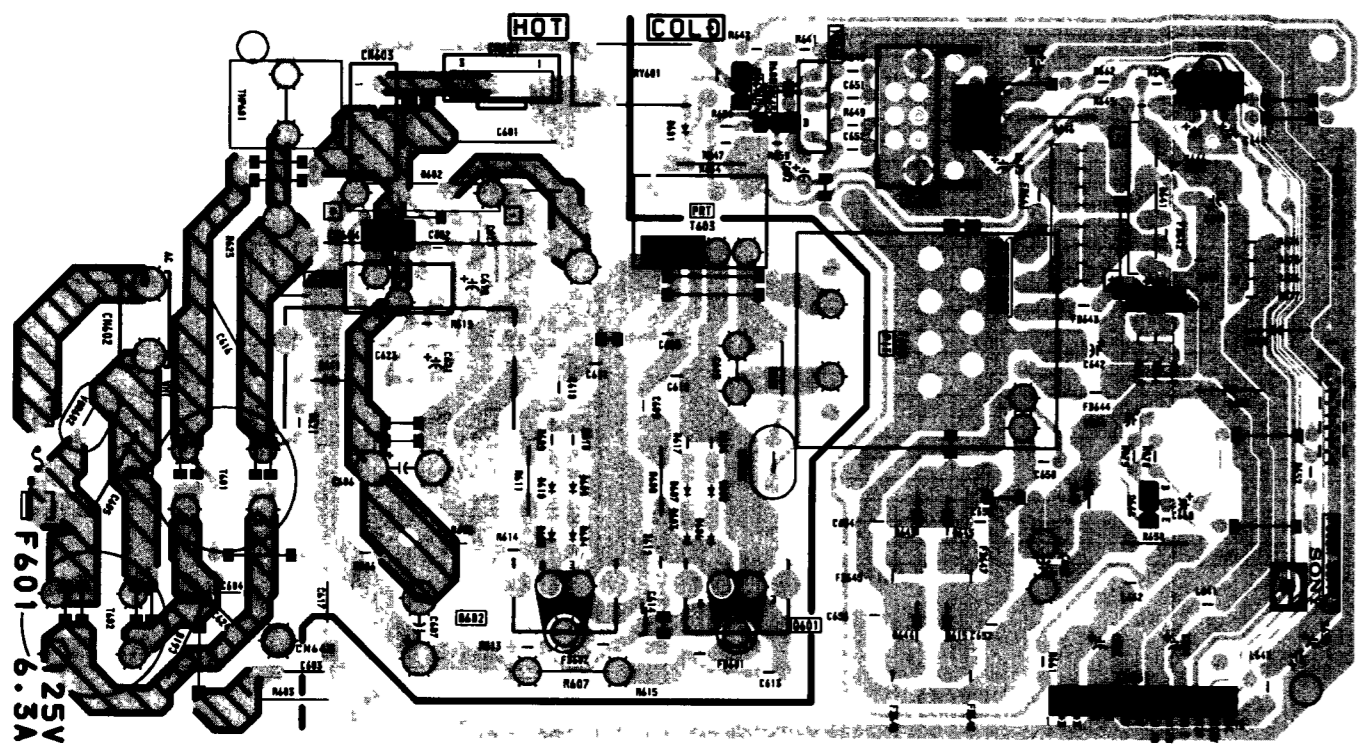

G BOARD (*) MARK LIST

	KV-27S22/ 27S26	KV-27S36	KV-29RS26C/ 29RS22C	KV-29RS26/29PS2/ 29SD2/29RS22
C602	#	#	4.7	#
C604	#	22 125V	#	#
C605	22/125V	22 125V	22/300V	22/125V
C608	680p/500V	680p/500V	001/500V	680p/500V
C617	1000p 250V	1000p 250V	1000p 250V	#
C626	JW(7.5)	JW(7.5)	100p/300V	JW(7.5)
C660	JW(5)	JW(5)	#	JW(5)
C661	4.7	4.7	#	4.7
F601	6.3A/125V	6.3A/125V	6.3A/250V	6.3A/125V
JW601	5MM	5MM	#	5MM
JW602	5MM	5MM	#	5MM
JW636	#	#	10MM	10MM
JW637	#	#	10MM	10MM
JW638	#	#	10MM	10MM
JW639	#	#	10MM	10MM
Q601	2SC4834MNP	2SC4834MNP	2SC4834NP	2SC4834MNP
Q602	2SC4834MNP	2SC4834MNP	2SC4834NP	2SC4834MNP
Q646	2SC3311A	2SC3311A	#	2SC3311A
R603	2.2M 1/2W	2.2M 1/2W	8.2M 1W	2.2M 1/2W
R608	1.8 2W	1.8 2W	1 2W	1.8 2W
R611	1.8 2W	1.8 2W	1 2W	1.8 2W
R623	1 20W	1 20W	3.9 20W	1 20W
R645	JW(5)	JW(5)	10 1/2W	JW(5)
R646	1 2W	JW(7.5)	JW(7.5)	1 2W
R659	#	#	10K	#
R678	22K	22K	#	22K
R679	22K	22K	#	22K
R680	10K	10K	#	10K
R681	150	150	JW(5)	150
RY601	1-755-018-11	1-755-146-11	1-755-018-11	1-755-018-11
T601	1-426-717-11	1-426-717-11	#	#
T602	1-424-220-21	1-424-220-21	1-426-717-11	1-426-717-11
TH601	1-809-539-21	1-809-539-21	1-809-827-11	1-809-539-21

Not Mounted

Schematic diagrams
 ← A board G C boards →

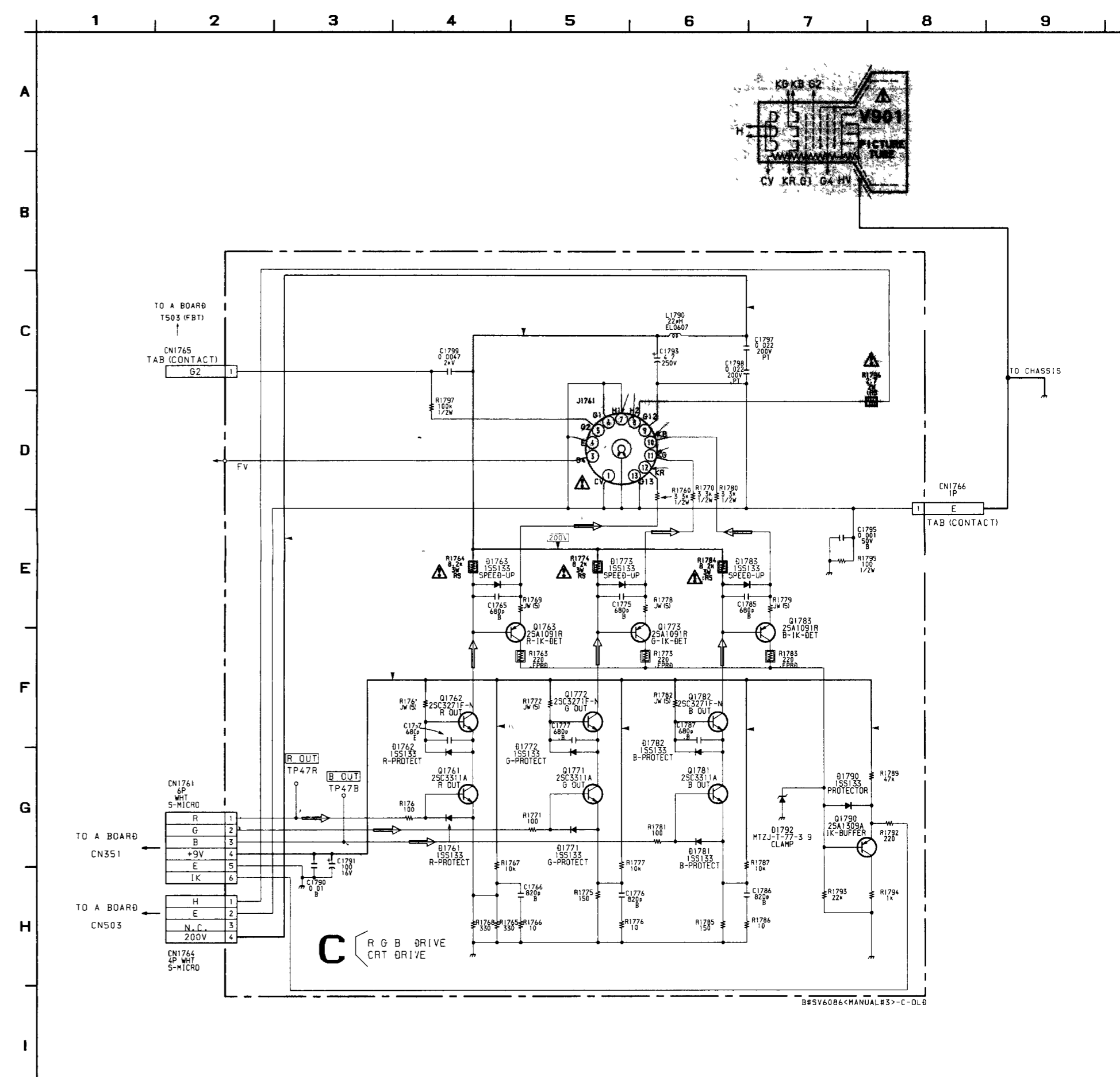

C [R,G,B DRIVE, CRT DRIVE]

— C BOARD —

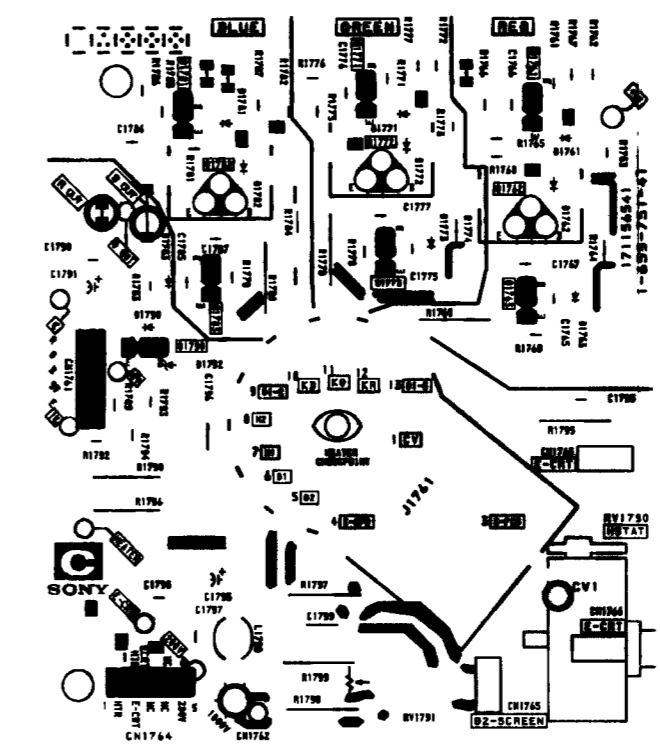

C BOARD WAVEFORMS

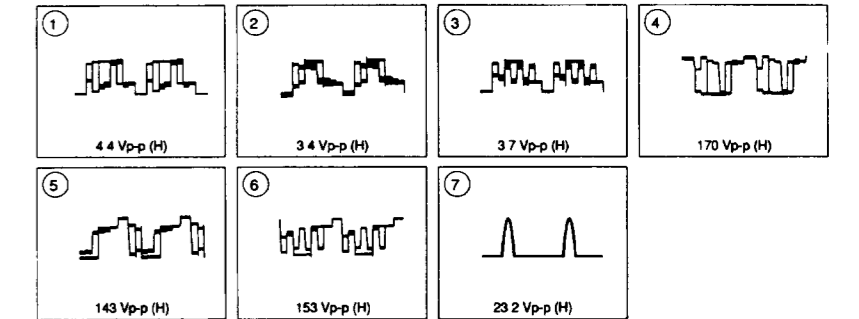

C BOARD TRANSISTOR VOLTAGE LIST

Q	B	C	E
Q1761	2.2	8.2	1.7
Q1762	8.7	134.1	8.2
Q1763	134.1	2.3	132.0
Q1771	1.8	8.2	1.3
Q1772	8.7	146.4	8.2
Q1773	146.4	2.3	144.1
Q1781	2.1	8.2	1.6
Q1782	8.7	133.7	8.2
Q1783	133.7	2.3	131.5
Q1790	2.2	0.2	2.5

All voltages are in V

G BOARD IC VOLTAGE LIST

IC	pin	volt
IC641	1	GND
	2	3.9
	3	8.9
	4	8.9
	5	10.5
IC642	IN	9.5
	OUT	5.0
IC643	1	135
	2	NC
	3	2.5
	4	7.8
	5	GND

All voltages are in V

G BOARD TRANSISTOR VOLTAGE LIST

Q	B	C	E
Q601	145.2	294.0	147.5
Q602	-1.7	147.5	GND
Q644	-0.3	10.5	GND
Q645	7.0	GND	7.6
Q646	4.8	7.4	4.8

All voltages are in V

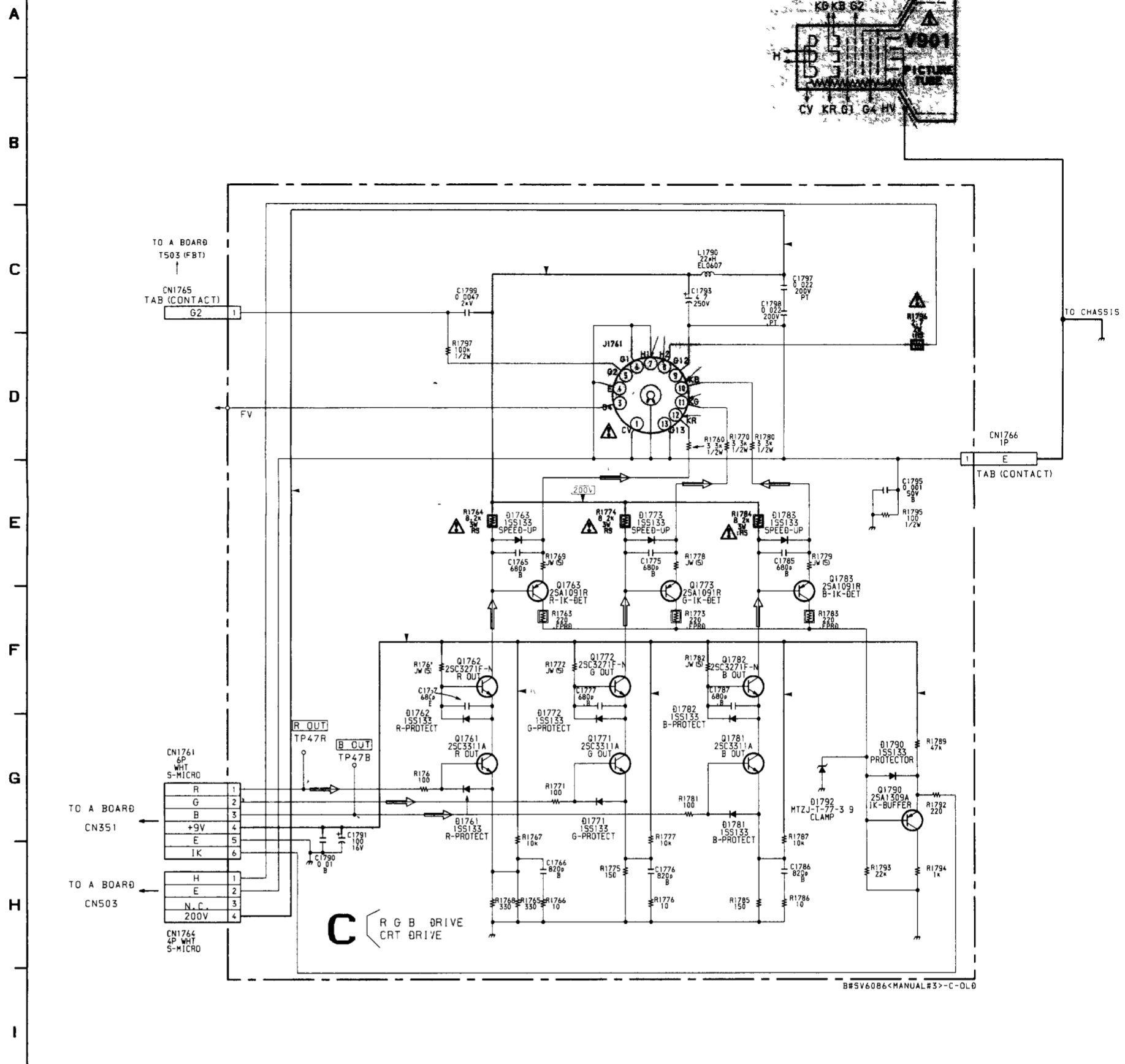

C [R,G,B DRIVE, CRT DRIVE]

— C BOARD —

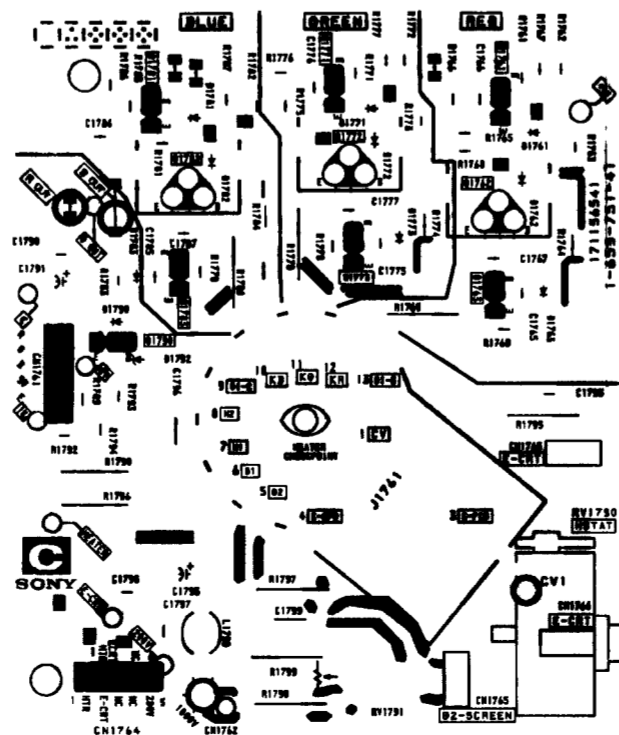

C BOARD WAVEFORMS

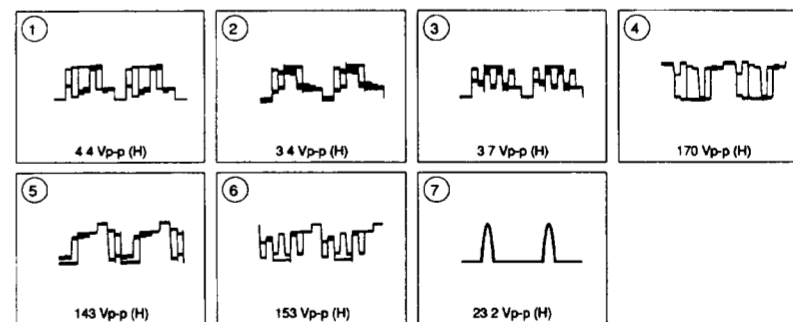

C BOARD TRANSISTOR VOLTAGE LIST

Q	B	C	E
Q1761	2.2	8.2	1.7
Q1762	8.7	134.1	8.2
Q1763	134.1	2.3	132.0
Q1771	1.8	8.2	1.3
Q1772	8.7	146.4	8.2
Q1773	146.4	2.3	144.1
Q1781	2.1	8.2	1.6
Q1782	8.7	133.7	8.2
Q1783	133.7	2.3	131.5
Q1790	2.2	0.2	2.5

All voltages are in V

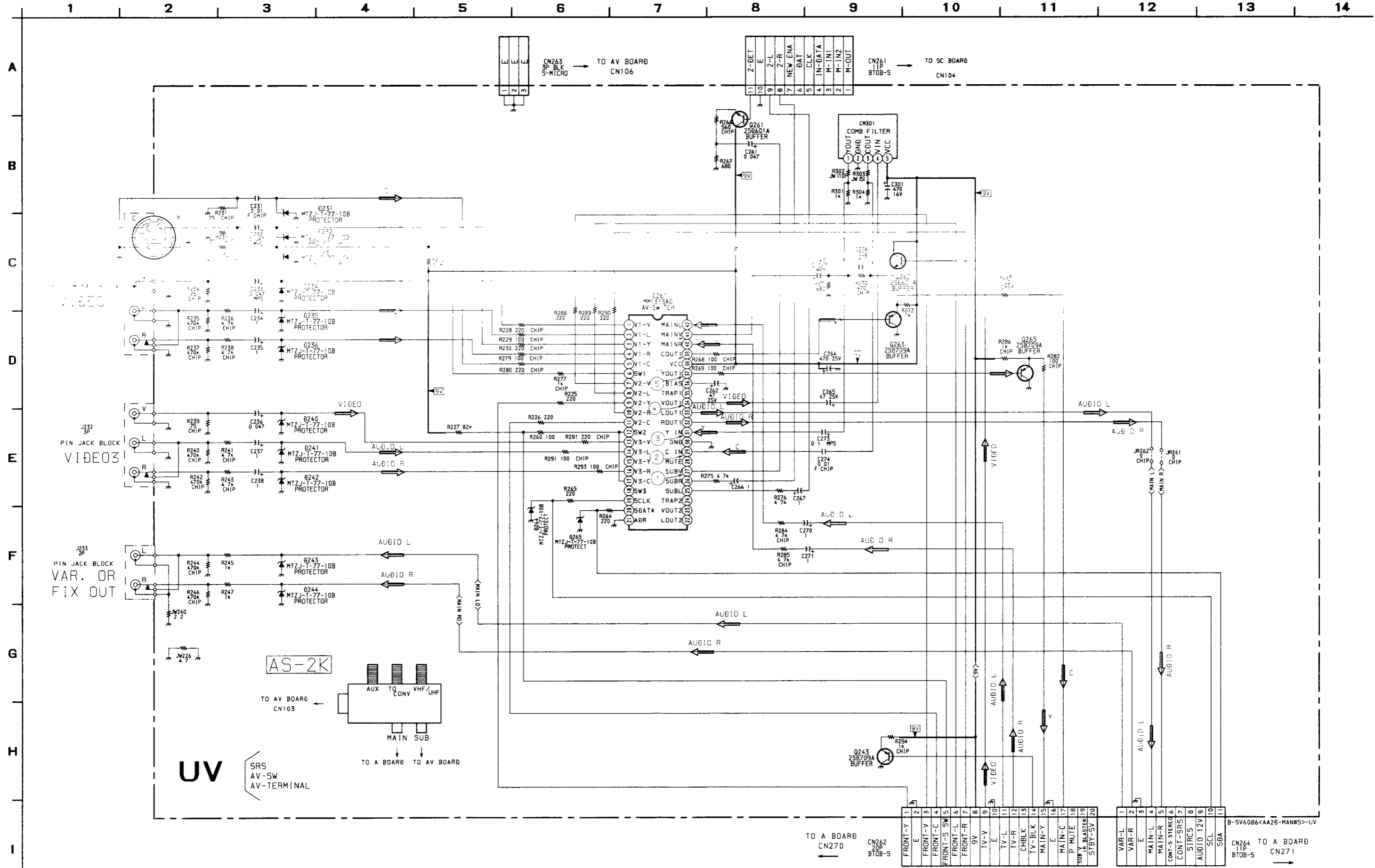

UV BOARD IC VOLTAGE LIST

IC261	
pin	volt
1	4.8
2	4.2
3	4.8
4	4.2
5	4.8
6	4.5
7	4.8
8	4.2
9	4.8
10	4.2
11	4.9
12	5.8
13	4.8
14	4.2
15	0
16	4.2
17	5.8
18	NC
19	5.0
20	4.9
21	GND
22	NC
23	NC
24	NC
25	4.2
26	4.2
27	6.1
28	NC
29	4.8
30	GND
31	5.6
32	4.1
33	4.1
34	5.0
35	NC
36	4.2
37	4.3
38	8.7
39	3.4
40	4.2
41	5.2
42	4.2

All voltages are in V

UV BOARD IC1261 MM1313AD

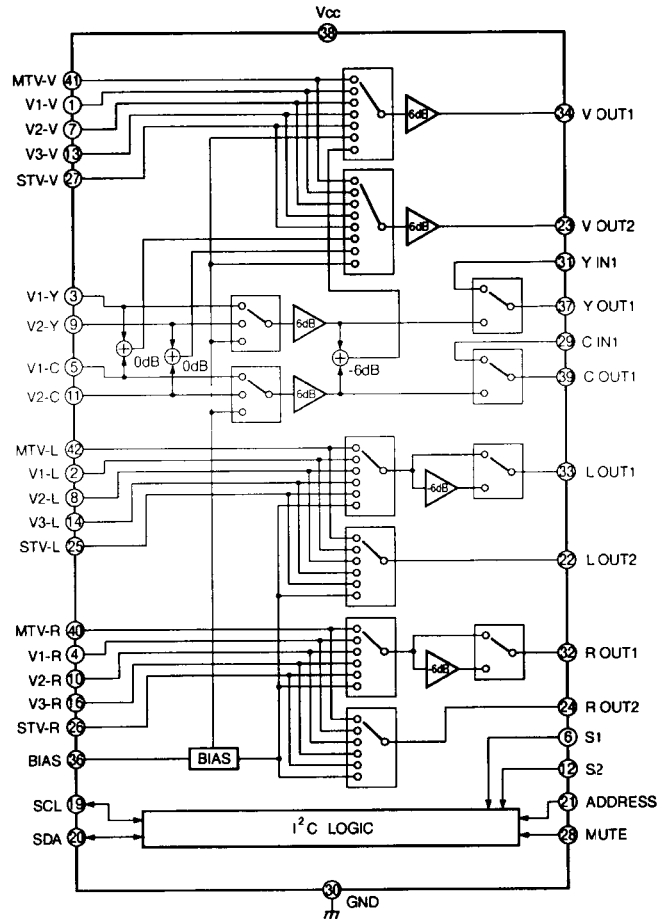

UV BOARD TRANSISTOR VOLTAGE LIST

	B	C	E
Q243	0.2	GND	0.9
Q261	4.6	8.7	4.0
Q262	4.9	8.7	4.2
Q263	3.4	GND	4.1
Q265	4.3	GND	4.9

All voltages are in V

UV BOARD WAVEFORMS

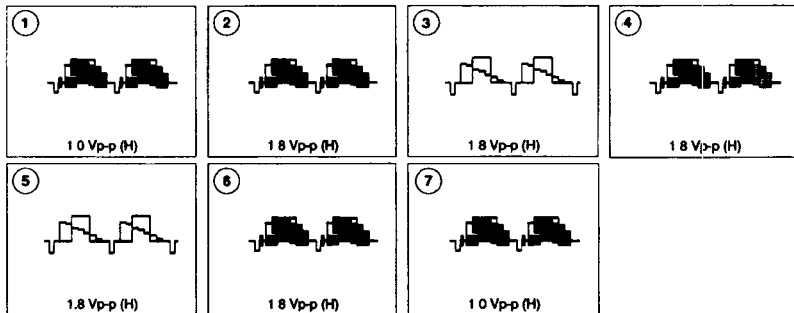



[2ND-TUNER, S-LINK]
 (KV-27S36 ONLY)

— AV BOARD —

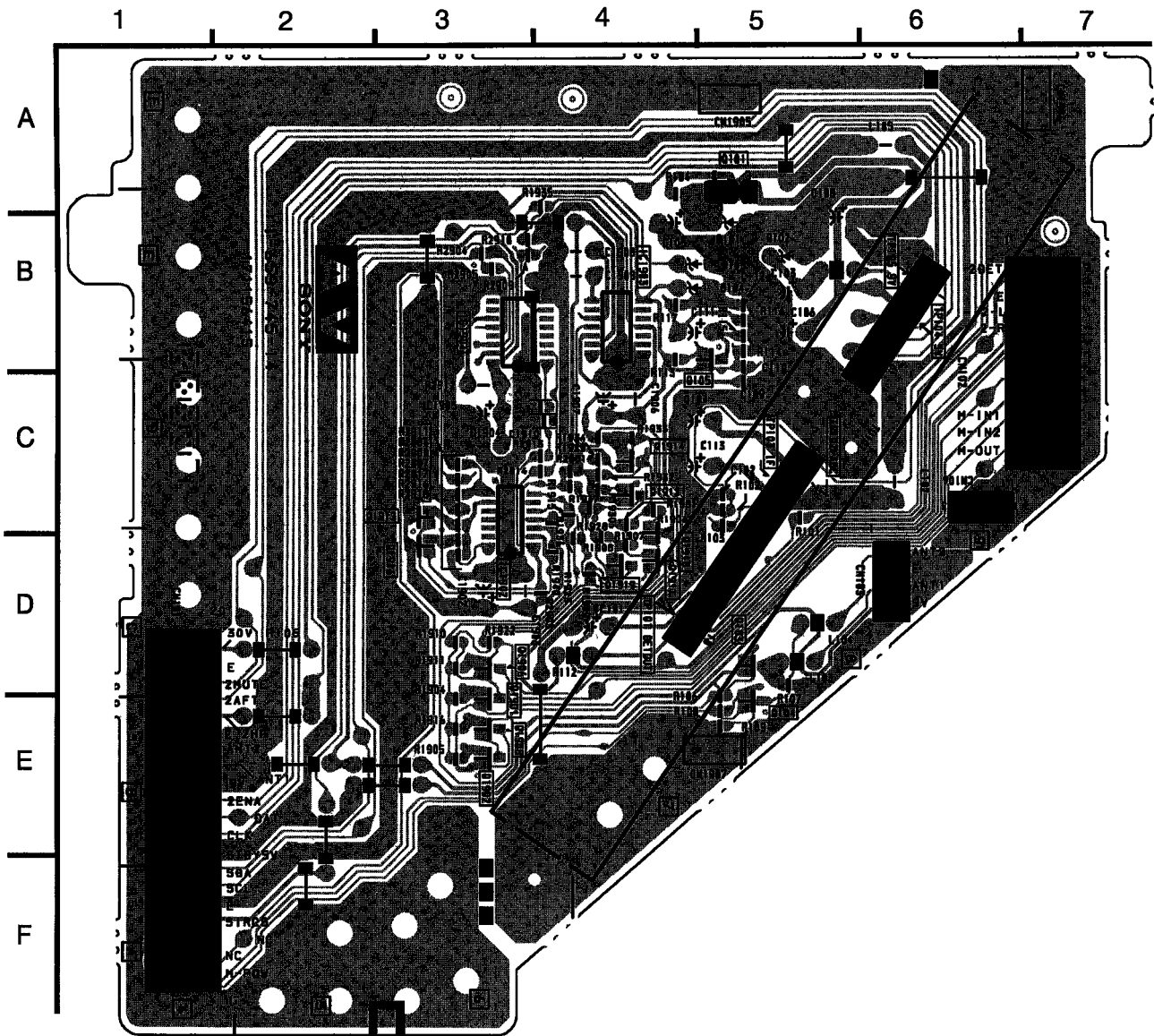

AV BOARD LOCATION

DIODE	
D101	B-5
D103	B-4
D104	B-4
TRANSISTOR	
Q101	A-5
Q103	D-5
Q104	D-5
Q105	B-4

4-4. SEMICONDUCTORS

BH3856FS-E2

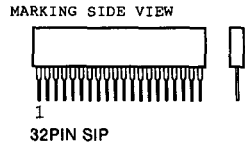

CXA1315M

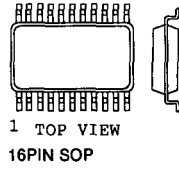

CXA2025AS

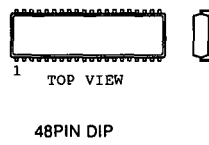

CXP85840-002S

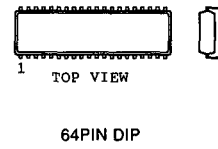

DM-58

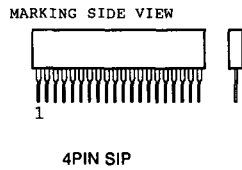

IS474

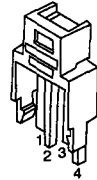

MM1311AD

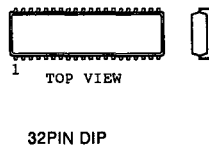

MM1313AD

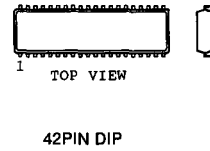

TDA8315T/N3A-T

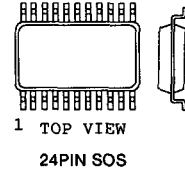

NJM2903M
ST24CO2FM6TR
UPC4558G2

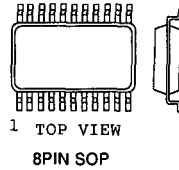

NJM78M05FA
TA7805S



SBX1981-51

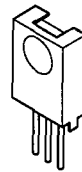

IRF614



SI3090CA

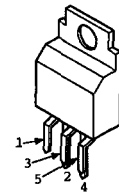

TDA8172

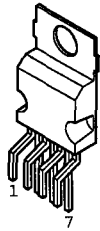

TDA2009A

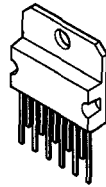

2SA1037AK-T146-R
2SA1162-G
2SA1130-06
2SD601A-Q

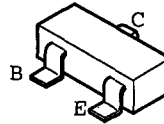

2SA1091-0



2SA1175-HFE
2SC2785-HFE

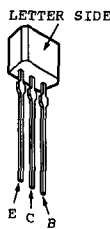

2SA1837
2SC4159-E

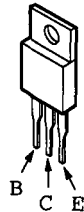

2SC2611

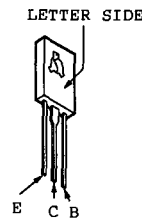

2SC4834M

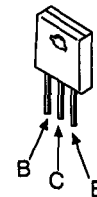

2SC3209LK

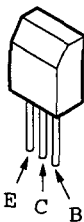

D10SC4M



D1NS4
MTZJ-3 3
MTZJ-33A
MTZJ-6 2B
MTZJ-7 5B
RD10ESB2
RD39ES-B2
RD5 6ESB2
1SS19-25

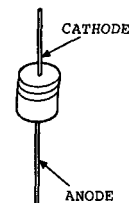

D2L2OU
EL1Z
EZ0150AV1
GP08D
MTZJ-T-77-3 9
RGP02-17EL-6433

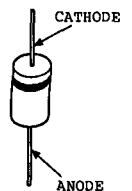

D4SB60L
RBA-1004B

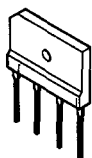

ERC06-15S
ISSI33T-77

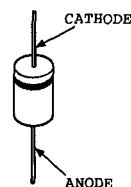

ERD29-08J

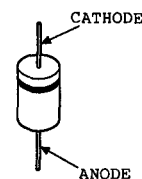

FMGAT148
2SC5418

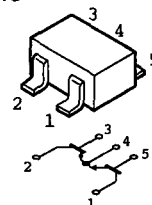

SECTION 5 EXPLODED VIEW

• Items with no part number and no description are not stocked because they are seldom required for routine service

• The component parts of an assembly are indicated by the reference numbers in the remarks column

• Items marked " * " are not stocked since they are seldom required for routine service. Some delay should be anticipated when ordering these items

Note

The components identified by shading and mark Δ are critical for safety. Replace only with part number specified.

Les composants identifiés par un trame et une marque Δ sont critiques pour la sécurité. Ne les remplacer que par une pièce portant le numéro spécifié.

5-1. CHASSIS

■ 7-685-663-79 SCREW +BVTP 4X16

● 7-685-648-79 +BVTP 3X12

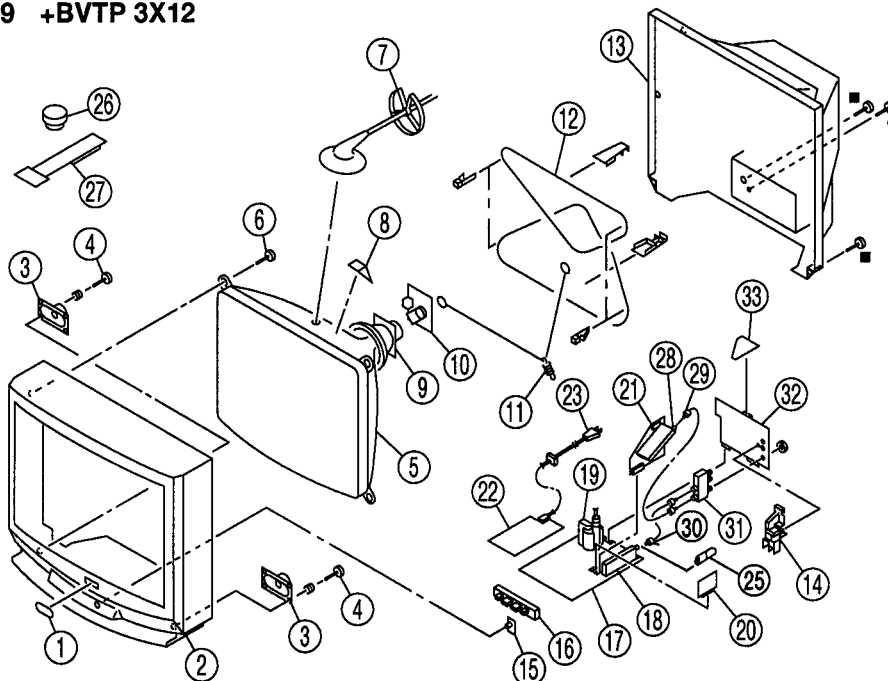

REF. NO.	PART NO.	DESCRIPTION	REMARK	REF. NO.	PART NO.	DESCRIPTION	REMARK
1	4-046-160-01	EMBLEM (NO 9), SONY		17	*	A-1298-061-A A BOARD, COMPLETE (KV-27S22/29RS22/29RS22C/29SD2/29PS2)	
2	4-059-086-01	BEZNET (KV-27S22/29RS22/29RS22C)		17	*	A-1298-162-A A BOARD, COMPLETE (27S26/29RS26/29RS26C)	
2	4-059-447-01	BEZNET (KV-27S26/29RS26/29RS26C)		17	*	A-1298-163-A A BOARD, COMPLETE (27S36)	
2	4-059-447-11	BEZNET (KV-29SD2/29PS2)					
2	4-059-447-21	BEZNET (KV-27S36)		18	Δ	8-598-340-00 TUNER BTF-WA405	
3	1-504-531-11	SPEAKER (13.1X6.2CM)		19	Δ	1-453-207-11 TRANSFORMER ASSY, FLYBACK NX-2609//X4C	
4	4-388-477-01	SCREW (3X16), TAPPING, +BV WASHER		20	*	A-1195-103-A P BOARD, COMPLETE (KV-27S26/27S36/29RS26/29RS26C)	
5	Δ 8-733-848-05	CRT 29PXD (A68KZJ50X) (EXCEPT KV-29RS22C/29RS26C)		21	*	A-1297-905-A AV BOARD, COMPLETE (KV-27S36)	
5	Δ 8-733-849-05	CRT 29PXD (A68KZJ50X) (KV-29RS22C/29RS26C)		22	*	A-1316-249-A G BOARD, COMPLETE (KV-27S22/27S26)	
6	4-041-268-01	SCREW (7), TAPPING		22	*	A-1316-252-A G BOARD, COMPLETE (KV-29RS22C/29RS26C)	
7	3-704-372-31	HOLDER, HV CABLE		22	*	A-1316-261-A G BOARD, COMPLETE (KV-27S36)	
8	4-053-005-01	SPACER, DY		22	*	A-1316-296-A G BOARD, COMPLETE (KV-29RS22/29RS26/29SD2/29PS2)	
9	Δ 8-451-275-42	DEFLECTION YOKE Y28PFA		23	Δ	1-751-059-11 CORD, POWER (WITH CONNECTOR) 10A/250V (EXCEPT KV-29RS22C/29RS26C)	
10	*	A-1331-549-A C BOARD, COMPLETE		23	Δ	1-769-796-41 CORD, POWER (WITH CONNECTOR) 10A/125V (KV-29RS22C/29RS26C)	
11	4-036-329-01	SPRING (B), TENSION		25		1-766-374-11 PLUG, F-PIN (EXCEPT KV-27S36)	
12	Δ 1-406-726-81	COIL, DEMAGNETIC (KV-29RS22C/29RS26C)		26		1-452-032-00 MAGNET, DISC	
12	Δ 1-411-899-11	COIL, DEMAGNETIC (EXCEPT KV-29RS22C/29RS26C)		27		X-4306-312-0 PERMALLOY CONVERGENCE	
13	4-054-519-01	COVER, REAR (KV-27S36)		28	Δ	8-598-339-00 TUNER BTF-LA402 (KV-27S36)	
13	4-052-462-01	COVER, REAR (KV-27S26/29RS26/29RS26C)		29	*	1-557-056-31 CABLE, P-P (KV-27S36)	
13	4-052-462-21	COVER, REAR (27S22/29RS22/29RS22C/29SD2/29PS2)		30	*	1-556-945-21 CABLE, P-P (KV-27S36)	
14	*	4-052-905-01 V5/6 BRACKET (KV-27S36)		31		8-598-414-00 CHANGER, ANTENNA AS-2K (KV-27S36)	
15	4-052-461-01	GUIDE, LED		32	*	A-1394-863-A UV BOARD, COMPLETE (KV-27S36)	
16	4-052-460-01	BUTTON, MULTI		33	*	A-1390-585-A SC BOARD, COMPLETE (KV-27S36)	

SECTION 6 ELECTRICAL PARTS LIST



Note

The components identified by shading and mark **Δ** are critical for safety. Replace only with part number specified.

Note:

Les composants identifiés par un trame et une marque **Δ** sont critiques pour la sécurité. Ne les remplacer que par une pièce portant le numéro spécifié.

The components identified by **Δ** in this manual have been carefully factory-selected for each set in order to satisfy regulations regarding X-ray radiation. Should replacement be required, replace only with the value originally used.

- Items marked "Δ" are not stocked since they are seldom required for routine service. Some delay should be anticipated when ordering these items.
- All variable and adjustable resistors have characteristic curve B, unless otherwise noted.

RESISTORS

- All resistors are in ohms
- F nonflammable

CAPACITORS

- MF = μF

INDUCTORS

UH = μH
MMH = mH

When indicating parts by reference number, please include the board name.

REF. NO.	PART NO.	DESCRIPTION	REMARK	REF. NO.	PART NO.	DESCRIPTION	REMARK
<div style="border: 1px solid black; padding: 5px; display: inline-block; font-size: 2em; font-weight: bold; margin-right: 10px;">P</div> <hr style="border: 1px solid black; width: 100%;"/> <p style="margin-top: 10px;">* A-1195-103-A P BOARD, COMPLETE (KV-27S26/27S36/29RS26/29RS26C ONLY)</p> <p style="margin-top: 10px;"><u>CAPACITOR</u></p>							
C3301	1-163-017-00	CERAMIC CHIP	0 0047MF 10% 50V	C3338	1-163-141-00	CERAMIC CHIP	0 001MF 5% 50V
C3302	1-164-346-11	CERAMIC CHIP	1MF 16V	C3340	1-163-031-11	CERAMIC CHIP	0 01MF 50V
C3303	1-163-038-91	CERAMIC CHIP	0 1MF 25V	C3346	1-163-251-11	CERAMIC CHIP	100PF 5% 50V
C3304	1-126-960-11	ELECT	1MF 20% 50V	C3347	1-126-960-11	ELECT	1MF 20% 50V
C3305	1-163-038-91	CERAMIC CHIP	0 1MF 25V	C3348	1-126-967-11	ELECT	47MF 20% 16V
C3306	1-126-967-11	ELECT	47MF 20% 16V	C3349	1-163-121-00	CERAMIC CHIP	150PF 5% 50V
C3307	1-163-038-91	CERAMIC CHIP	0 1MF 25V	C3350	1-164-004-11	CERAMIC CHIP	0 1MF 10% 25V
C3308	1-163-231-11	CERAMIC CHIP	15PF 5% 50V	C3351	1-163-251-11	CERAMIC CHIP	100PF 5% 50V
C3309	1-163-017-00	CERAMIC CHIP	0 0047MF 10% 50V	<u>CONNECTOR</u>			
C3310	1-164-004-11	CERAMIC CHIP	0 1MF 10% 25V	CN3301*	1-764-816-11	CONNECTOR, BOARD TO BOARD 20P	
C3313	1-163-038-91	CERAMIC CHIP	0 1MF 25V	<u>IC</u>			
C3314	1-163-038-91	CERAMIC CHIP	0 1MF 25V	IC3301	8-759-366-24	IC TDA8315T/N3A-T	
C3315	1-164-346-11	CERAMIC CHIP	1MF 16V	IC3302	8-759-231-53	IC TA7805S	
C3319	1-163-031-11	CERAMIC CHIP	0 01MF 50V	IC3303	8-759-438-61	IC SDA9288X-A141	
C3320	1-126-960-11	ELECT	1MF 20% 50V	<u>COIL</u>			
C3321	1-163-239-11	CERAMIC CHIP	33PF 5% 50V	L3301	1-408-413-00	INDUCTOR	22UH
C3322	1-163-239-11	CERAMIC CHIP	33PF 5% 50V	L3302	1-410-473-11	INDUCTOR	18UH
C3323	1-163-031-11	CERAMIC CHIP	0 01MF 50V	L3303	1-408-418-00	INDUCTOR	56UH
C3324	1-126-967-11	ELECT	47MF 20% 16V	<u>TRANSISTOR</u>			
C3325	1-163-038-91	CERAMIC CHIP	0 1MF 25V	Q3301	8-729-422-27	TRANSISTOR 2SD601A-Q	
C3326	1-163-038-91	CERAMIC CHIP	0 1MF 25V	Q3305	8-729-216-22	TRANSISTOR 2SA1162-G	
C3327	1-163-038-91	CERAMIC CHIP	0 1MF 25V	Q3306	8-729-216-22	TRANSISTOR 2SA1162-G	
C3328	1-126-967-11	ELECT	47MF 20% 16V	Q3307	8-729-216-22	TRANSISTOR 2SA1162-G	
C3329	1-126-967-11	ELECT	47MF 20% 16V	Q3308	8-729-422-27	TRANSISTOR 2SD601A-Q	
C3330	1-163-031-11	CERAMIC CHIP	0 01MF 50V	Q3310	8-729-422-27	TRANSISTOR 2SD601A-Q	
C3331	1-126-967-11	ELECT	47MF 20% 16V	Q3312	8-729-216-22	TRANSISTOR 2SA1162-G	
C3332	1-104-664-11	ELECT	47MF 20% 25V	Q3313	8-729-422-27	TRANSISTOR 2SD601A-Q	
C3333	1-164-695-11	CERAMIC CHIP	0 0022MF 5% 50V	<u>RESISTOR</u>			
C3334	1-163-031-11	CERAMIC CHIP	0 01MF 50V	R3301	1-216-075-00	METAL GLAZE	12K 5% 1/10W
C3335	1-163-038-91	CERAMIC CHIP	0 1MF 25V	R3302	1-216-043-91	METAL GLAZE	560 5% 1/10W
C3336	1-163-038-91	CERAMIC CHIP	0 1MF 25V	R3303	1-216-295-91	CONDUCTOR, CHIP (2012)	
C3337	1-164-005-11	CERAMIC CHIP	0 47MF 25V	R3304	1-216-043-91	METAL GLAZE	560 5% 1/10W
				R3306	1-215-882-00	METAL OXIDE	22 5% 2W F
				R3307	1-216-097-91	METAL GLAZE	100K 5% 1/10W



Note The components identified by shading and mark Δ are critical for safety
Replace only with part number specified

Note Les composants identifiés par un trame et une marque Δ sont critiques pour la sécurité. Ne les remplacer que par une pièce portant le numéro spécifié

REF.NO.	PART NO.	DESCRIPTION	REMARK
R3308	1-216-051-00	METAL GLAZE	1 2K 5% 1/10W
R3309	1-216-051-00	METAL GLAZE	1 2K 5% 1/10W
R3310	1-216-689-11	METAL GLAZE	39K 5% 1/10W
R3311	1-216-689-11	METAL GLAZE	39K 5% 1/10W
R3312	1-216-037-00	METAL GLAZE	330 5% 1/10W
R3313	1-216-041-00	METAL GLAZE	470 5% 1/10W
R3314	1-216-041-00	METAL GLAZE	470 5% 1/10W
R3315	1-216-041-00	METAL GLAZE	470 5% 1/10W
R3316	1-216-053-00	METAL GLAZE	1 5K 5% 1/10W
R3319	1-216-053-00	METAL GLAZE	1 5K 5% 1/10W
R3321	1-216-053-00	METAL GLAZE	1 5K 5% 1/10W
R3322	1-216-065-00	METAL GLAZE	4 7K 5% 1/10W
R3323	1-216-065-00	METAL GLAZE	4 7K 5% 1/10W
R3324	1-216-065-00	METAL GLAZE	4 7K 5% 1/10W
R3326	1-216-037-00	METAL GLAZE	330 5% 1/10W
R3327	1-216-031-00	METAL GLAZE	180 5% 1/10W
R3328	1-216-037-00	METAL GLAZE	330 5% 1/10W
R3329	1-216-069-00	METAL GLAZE	6 8K 5% 1/10W
R3330	1-216-035-00	METAL GLAZE	270 5% 1/10W
R3331	1-216-073-00	METAL GLAZE	10K 5% 1/10W
R3332	1-216-041-00	METAL GLAZE	470 5% 1/10W
R3337	1-216-033-00	METAL GLAZE	220 5% 1/10W
R3338	1-216-033-00	METAL GLAZE	220 5% 1/10W
R3339	1-216-041-00	METAL GLAZE	470 5% 1/10W
R3340	1-216-041-00	METAL GLAZE	470 5% 1/10W
R3341	1-216-057-00	METAL GLAZE	2 2K 5% 1/10W
R3342	1-216-057-00	METAL GLAZE	2 2K 5% 1/10W
R3343	1-216-049-91	METAL GLAZE	1K 5% 1/10W
R3346	1-216-049-91	METAL GLAZE	1K 5% 1/10W
R3351	1-216-295-91	CONDUCTOR, CHIP	(2012)
R3352	1-216-049-91	METAL GLAZE	1K 5% 1/10W
R3358	1-216-047-91	METAL GLAZE	820 5% 1/10W
R3359	1-216-047-91	METAL GLAZE	820 5% 1/10W
R3360	1-216-053-00	METAL GLAZE	1 5K 5% 1/10W
R3361	1-216-053-00	METAL GLAZE	1.5K 5% 1/10W
R3362	1-216-029-00	METAL GLAZE	150 5% 1/10W
R3363	1-216-031-00	METAL GLAZE	180 5% 1/10W
R3364	1-216-035-00	METAL GLAZE	270 5% 1/10W
R3365	1-216-105-91	METAL GLAZE	220K 5% 1/10W
R3366	1-216-105-91	METAL GLAZE	220K 5% 1/10W
R3367	1-216-095-00	METAL GLAZE	82K 5% 1/10W
R3368	1-216-103-00	METAL GLAZE	180K 5% 1/10W
R3369	1-216-101-00	METAL GLAZE	150K 5% 1/10W
R3370	1-216-041-00	METAL GLAZE	470 5% 1/10W
R3371	1-216-095-00	METAL GLAZE	82K 5% 1/10W
R3372	1-216-041-00	METAL GLAZE	470 5% 1/10W
R3373	1-216-035-00	METAL GLAZE	270 5% 1/10W

REF NO.	PART NO.	DESCRIPTION	REMARK
---------	----------	-------------	--------

CRYSTAL

X3301	1-567-505-11	OSCILLATOR, CRYSTAL	
-------	--------------	---------------------	--

X3302	1-760-095-21	VIBRATOR, CRYSTAL	
-------	--------------	-------------------	--



* A-1297-905-A AV BOARD, COMPLETE (KV-27S36 ONLY)

CAPACITOR

C101	1-126-960-11	ELECT	1MF	20%	50V
C102	1-164-161-11	CERAMIC CHIP	0 0022MF	10%	50V
C104	1-126-964-11	ELECT	10MF	20%	50V
C106	1-104-664-11	ELECT	47MF	20%	25V
C108	1-126-933-11	ELECT	100MF	20%	16V

C109	1-163-259-91	CERAMIC CHIP	220PF	5%	50V
C110	1-104-760-11	CERAMIC CHIP	0 047MF	10%	50V
C111	1-126-960-11	ELECT	1MF	20%	50V
C113	1-126-934-11	ELECT	220MF	20%	16V

CONNECTOR

CN101	1-573-301-21	CONNECTOR, BOARD TO BOARD	20P
CN102	1-573-979-21	CONNECTOR, BOARD TO BOARD	11P
CN103 *	1-564-507-11	PLUG, CONNECTOR	4P
CN106 *	1-564-506-11	PLUG, CONNECTOR	3P

DIODE

D101	8-719-109-89	DIODE RD5 6ESB2
D103	8-719-991-33	DIODE 1SS133T-77
D104	8-719-991-33	DIODE 1SS133T-77

COIL

L102	1-410-470-11	INDUCTOR	10UH
L105	1-408-421-00	INDUCTOR	100UH

TRANSISTOR

Q101	8-729-119-78	TRANSISTOR 2SC2785-HFE
Q103	8-729-216-22	TRANSISTOR 2SA1162-G
Q104	8-729-216-22	TRANSISTOR 2SA1162-G
Q105	8-729-216-22	TRANSISTOR 2SA1162-G

RESISTOR

R101	1-216-065-00	METAL GLAZE	4 7K	5%	1/10W
R102	1-216-083-00	METAL GLAZE	27K	5%	1/10W
R103	1-216-689-11	METAL GLAZE	39K	5%	1/10W
R104	1-216-045-00	METAL GLAZE	680	5%	1/10W
R106	1-216-081-00	METAL GLAZE	22K	5%	1/10W
R107	1-216-081-00	METAL GLAZE	22K	5%	1/10W
R108	1-216-081-00	METAL GLAZE	22K	5%	1/10W

Note: The components identified by shading and mark Δ are critical for safety. Replace only with part number specified.

Note: Les composants identifiés par un trame et une marque Δ sont critiques pour la sécurité. Ne les remplacer que par une pièce portant le numéro spécifié.



REF.NO.	PART NO.	DESCRIPTION	REMARK
R109	1-216-081-00	METAL GLAZE	22K 5% 1/10W
R112	1-249-421-11	CARBON	2 2K 5% 1/4W
R113	1-216-097-91	METAL GLAZE	100K 5% 1/10W
R114	1-216-121-91	METAL GLAZE	1M 5% 1/10W
R115	1-216-073-00	METAL GLAZE	10K 5% 1/10W
R116	1-216-073-00	METAL GLAZE	10K 5% 1/10W
R117	1-216-065-00	METAL GLAZE	4 7K 5% 1/10W

TUNER

TU101 Δ 8-598-339-00 TUNER, FSS BTF-LA402



- * A-1298-061-A A BOARD, COMPLETE
(KV-27S22/29PS2/29SD2/29RS22/29RS22C)
- * A-1298-162-A A BOARD, COMPLETE
(KV-27S26/29RS26/29RS26C)
- * A-1298-163-A A BOARD, COMPLETE (KV-27S36)
- * 4-051-927-01 CASE, SHIELD
- * 4-382-854-11 SCREW (M3X10), P, SW (+)

CAPACITOR

C001	1-163-259-91	CERAMIC CHIP	220PF 5% 50V
C003	1-104-760-11	CERAMIC CHIP	0.047MF 10% 50V
C005	1-126-960-11	ELECT	1MF 20% 50V
C009	1-126-967-11	ELECT	47MF 20% 50V
C010	1-163-033-91	CERAMIC CHIP	0 022MF 50V
C012	1-216-033-00	METAL GLAZE	220 5% 1/10W
C013	1-216-121-91	METAL GLAZE	1M 5% 1/10W
C014	1-164-161-11	CERAMIC CHIP	0 0022MF 10% 50V
C023	1-163-259-91	CERAMIC CHIP	220PF 5% 50V
C028	1-163-227-11	CERAMIC CHIP	10PF 0 5PF 50V
C029	1-163-227-11	CERAMIC CHIP	10PF 0 5PF 50V
C035	1-163-237-11	CERAMIC CHIP	27PF 5% 50V
C036	1-163-231-11	CERAMIC CHIP	15PF 5% 50V
C037	1-163-243-11	CERAMIC CHIP	47PF 5% 50V
C038	1-163-243-11	CERAMIC CHIP	47PF 5% 50V
C039	1-163-243-11	CERAMIC CHIP	47PF 5% 50V
C040	1-163-243-11	CERAMIC CHIP	47PF 5% 50V
C051	1-164-161-11	CERAMIC CHIP	0 0022MF 10% 50V
C053	1-164-232-11	CERAMIC CHIP	0 01MF 10% 50V
C056	1-163-243-11	CERAMIC CHIP	47PF 5% 50V
C061	1-163-033-91	CERAMIC CHIP	0 022MF 50V
C062	1-163-033-91	CERAMIC CHIP	0.022MF 50V
C063	1-126-935-11	ELECT	470MF 20% 16V
C068	1-164-096-11	CERAMIC	0 01MF 50V
C071	1-164-096-11	CERAMIC	0.01MF 50V

REF.NO.	PART NO.	DESCRIPTION	REMARK
C072	1-164-161-11	CERAMIC CHIP	0 0022MF 10% 50V
C075	1-107-823-11	CERAMIC CHIP	0 47MF 10% 16V
C353	1-163-231-11	CERAMIC CHIP	15PF 5% 50V
C354	1-163-133-00	CERAMIC CHIP	470PF 5% 50V
C355	1-126-959-11	ELECT	0 47MF 20% 50V
C356	1-126-963-11	ELECT	4 7MF 20% 50V
C357	1-126-959-11	ELECT	0 47MF 20% 50V
C358	1-164-232-11	CERAMIC CHIP	0 01MF 10% 50V
C359	1-126-933-11	ELECT	100MF 20% 16V
C363	1-164-232-11	CERAMIC CHIP	0 01MF 10% 50V
C364	1-164-232-11	CERAMIC CHIP	0 01MF 10% 50V
C365	1-164-232-11	CERAMIC CHIP	0 01MF 10% 50V
C366	1-137-399-11	FILM	0 1MF 5% 50V
C367	1-137-399-11	FILM	0 1MF 5% 50V
C368	1-137-399-11	FILM	0.1MF 5% 50V
C369	1-163-243-11	CERAMIC CHIP	47PF 5% 50V
C370	1-163-037-11	CERAMIC CHIP	0 022MF 10% 50V
C371	1-163-141-00	CERAMIC CHIP	0 001MF 5% 50V
C372	1-126-959-11	ELECT	0 47MF 20% 50V
C373	1-126-960-11	ELECT	1MF 20% 50V
C375	1-165-319-11	CERAMIC CHIP	0 1MF 50V (KV-27S22/29RS22/29RS22C/29SD2/29PS2)
C376	1-126-964-11	ELECT	10MF 20% 50V
C377	1-137-399-11	FILM	0.1MF 5% 50V
C378	1-136-244-11	FILM	0.1MF 5% 50V
C379	1-164-232-11	CERAMIC CHIP	0 01MF 10% 50V
C380	1-126-935-11	ELECT	470MF 20% 16V
C381	1-163-003-11	CERAMIC CHIP	330PF 10% 50V
C383	1-137-399-11	FILM	0.1MF 5% 50V
C385	1-164-182-11	CERAMIC CHIP	0 0033MF 10% 50V
C386	1-164-232-11	CERAMIC CHIP	0 01MF 10% 50V
C387	1-126-961-11	ELECT	2 2MF 20% 50V
C388	1-126-959-11	ELECT	0 47MF 20% 50V
C390	1-126-960-11	ELECT	1MF 20% 50V
C391	1-163-017-00	CERAMIC CHIP	0 0047MF 10% 50V
C392	1-163-251-11	CERAMIC CHIP	100PF 5% 50V
C461	1-126-933-11	ELECT	100MF 20% 16V
C462	1-126-961-11	ELECT	2 2MF 20% 50V
C463	1-126-961-11	ELECT	2 2MF 20% 50V
C466	1-104-666-11	ELECT	220MF 20% 25V
C468	1-104-664-11	ELECT	47MF 20% 25V
C470	1-126-961-11	ELECT	2 2MF 20% 50V
C471	1-104-666-11	ELECT	220MF 20% 25V
C472	1-136-173-00	FILM	0 47MF 5% 50V
C473	1-136-169-00	FILM	0 22MF 5% 50V
C474	1-126-942-61	ELECT	1000MF 20% 25V
C475	1-136-169-00	FILM	0 22MF 5% 50V
C476	1-126-942-61	ELECT	1000MF 20% 25V
C477	1-126-942-61	ELECT	1000MF 20% 25V



Note: The components identified by shading and mark Δ are critical for safety. Replace only with part number specified

Note: Les composants identifiés par un trame et une marque Δ sont critiques pour la sécurité. Ne les remplacer que par une pièce portant le numéro spécifié

REF.NO.	PART NO.	DESCRIPTION	REMARK
C501	1-102-110-00	CERAMIC	220PF 10% 50V
C502	1-126-959-11	ELECT	0.47MF 20% 50V
C503	1-163-003-11	CERAMIC CHIP	330PF 10% 50V
C504	1-102-212-00	CERAMIC	820PF 10% 500V
C505	1-102-002-00	CERAMIC	680PF 10% 500V
C506	1-106-383-00	MYLAR	0.047MF 10% 200V
C507 Δ	1-162-116-00	CERAMIC	680PF 10% 2KV
C508	1-102-244-00	CERAMIC	220PF 10% 500V
C509	1-162-116-00	CERAMIC	680PF 10% 2KV
C510	1-137-150-11	MYLAR	0.01MF 10% 100V
C511 Δ	1-115-460-11	FILM	0.022MF 3% 1.2KV
C513 Δ	1-130-895-00	FILM	0.056MF 5% 400V
C514 Δ	1-104-844-11	FILM	0.62MF 5% 200V
C515	1-106-343-00	MYLAR	0.001MF 10% 100V
C516	1-115-461-11	FILM	2MF 5% 200V
C517	1-107-649-11	ELECT	2.2MF 20% 250V
C518	1-106-395-00	MYLAR	0.15MF 10% 200V
C519	1-162-815-11	CERAMIC	47PF 5% 500V
C520	1-164-646-11	CERAMIC	2200PF 10% 500V
C521	1-164-161-11	CERAMIC CHIP	0.0022MF 10% 50V
C522	1-126-960-11	ELECT	1MF 20% 50V
C525	1-102-244-00	CERAMIC	220PF 10% 500V
C526	1-107-662-11	ELECT	22MF 20% 250V
C527	1-162-116-00	CERAMIC	680PF 10% 2KV
C528	1-164-161-11	CERAMIC CHIP	0.0022MF 10% 50V
C529	1-128-551-11	ELECT	22MF 20% 25V
C530	1-137-366-11	FILM	0.0022MF 5% 50V
C531	1-126-965-11	ELECT	22MF 20% 50V
C532	1-126-965-11	ELECT	22MF 20% 50V
C537	1-126-941-11	ELECT	470MF 20% 25V
C539 Δ	1-126-935-11	ELECT	470MF 20% 16V
C540	1-123-024-21	ELECT	33MF 160V
C541	1-128-560-11	ELECT	22MF 20% 100V
C545	1-106-387-00	MYLAR	0.068MF 10% 200V
C546	1-106-343-00	MYLAR	0.001MF 10% 100V
C547	1-106-343-00	MYLAR	0.001MF 10% 100V
C551	1-163-037-11	CERAMIC CHIP	0.022MF 10% 50V
C561	1-126-967-11	ELECT	47MF 20% 50V
C563	1-126-923-11	ELECT	220MF 20% 10V
C564	1-126-960-11	ELECT	1MF 20% 50V
C565	1-126-969-11	ELECT	220MF 20% 50V
C566	1-126-964-11	ELECT	10MF 20% 50V
C568	1-136-169-00	FILM	0.22MF 5% 50V
C571	1-104-664-11	ELECT	47MF 20% 25V
C1002	1-126-964-11	ELECT	10MF 20% 50V
C1101	1-126-768-11	ELECT	2200MF 20% 16V
C1103	1-126-965-11	ELECT	22MF 20% 50V
C1104	1-126-967-11	ELECT	47MF 20% 16V
C1105	1-126-967-11	ELECT	47MF 20% 16V
C1106	1-126-964-11	ELECT	10MF 20% 50V

REF.NO.	PART NO.	DESCRIPTION	REMARK
C1107	1-163-037-11	CERAMIC CHIP	0.022MF 10% 50V
C1108	1-126-960-11	ELECT	1MF 20% 50V
C1109	1-126-964-11	ELECT	10MF 20% 50V
C1110	1-163-227-11	CERAMIC CHIP	10PF 0.5PF 50V
C1111	1-163-227-11	CERAMIC CHIP	10PF 0.5PF 50V
C1112	1-163-227-11	CERAMIC CHIP	10PF 0.5PF 50V
C1236	1-163-031-11	CERAMIC CHIP	0.01MF 50V (KV-27S26/29RS26/29RS26C)
C1237	1-136-161-00	FILM	0.047MF 5% 50V (KV-27S26/29RS26/29RS26C)
C1238	1-136-161-00	FILM	0.047MF 5% 50V (EXCEPT KV-27S36)
C1239	1-126-960-11	ELECT	1MF 20% 50V (EXCEPT KV-27S36)
C1240	1-126-960-11	ELECT	1MF 20% 50V (EXCEPT KV-27S36)
C1241	1-136-161-00	FILM	0.047MF 5% 50V (KV-27S26/29RS26/29RS26C)
C1242	1-126-960-11	ELECT	1MF 20% 50V (KV-27S26/29RS26/29RS26C)
C1243	1-126-960-11	ELECT	1MF 20% 50V (KV-27S26/29RS26/29RS26C)
C1244	1-126-959-11	ELECT	0.47MF 20% 50V
C1245	1-126-959-11	ELECT	0.47MF 20% 50V
C1261	1-126-967-11	ELECT	47MF 20% 16V (EXCEPT KV-27S36)
C1262	1-126-967-11	ELECT	47MF 20% 16V (EXCEPT KV-27S36)
C1263	1-126-960-11	ELECT	1MF 20% 50V (EXCEPT KV-27S36)
C1264	1-126-960-11	ELECT	1MF 20% 50V (EXCEPT KV-27S36)
C1265	1-136-165-00	FILM	0.1MF 5% 50V (EXCEPT KV-27S36)
C1266	1-126-967-11	ELECT	47MF 20% 16V (EXCEPT KV-27S36)
C1267	1-136-161-00	FILM	0.047MF 5% 50V (EXCEPT KV-27S36)
C1268	1-126-960-11	ELECT	1MF 20% 50V (EXCEPT KV-27S36)
C1269	1-126-960-11	ELECT	1MF 20% 50V (EXCEPT KV-27S36)
C1270	1-164-232-11	CERAMIC CHIP	0.01MF 10% 50V (EXCEPT KV-27S36)
C1293	1-163-251-11	CERAMIC CHIP	100PF 5% 50V (EXCEPT KV-27S36)
C1351	1-163-251-11	CERAMIC CHIP	100PF 5% 50V
C1352	1-126-933-11	ELECT	100MF 20% 16V
C1353	1-163-037-11	CERAMIC CHIP	0.022MF 10% 50V
C1354	1-216-295-91	CONDUCTOR, CHIP	(2012)
C1401	1-126-959-11	ELECT	0.47MF 20% 50V
C1402	1-126-964-11	ELECT	10MF 20% 50V
C1403	1-126-959-11	ELECT	0.47MF 20% 50V

Note: The components identified by shading and mark Δ are critical for safety. Replace only with part number specified.

Note: Les composants identifiés par un trame et une marque Δ sont critiques pour la sécurité. Ne les remplacer que par une pièce portant le numéro spécifique.



REF.NO.	PART NO.	DESCRIPTION	REMARK
C1404	1-165-319-11	CERAMIC CHIP	0.1MF 50V
C1405	1-165-319-11	CERAMIC CHIP	0.1MF 50V
C1406	1-165-319-11	CERAMIC CHIP	0.1MF 50V
C1407	1-165-319-11	CERAMIC CHIP	0.1MF 50V
C1408	1-164-161-11	CERAMIC CHIP	0.0022MF 10% 50V
C1409	1-164-161-11	CERAMIC CHIP	0.0022MF 10% 50V
C1410	1-164-161-11	CERAMIC CHIP	0.0022MF 10% 50V
C1411	1-164-161-11	CERAMIC CHIP	0.0022MF 10% 50V
C1412	1-126-961-11	ELECT	2.2MF 20% 50V
C1413	1-126-961-11	ELECT	2.2MF 20% 50V
C1414	1-164-489-11	CERAMIC CHIP	0.22MF 10% 16V
C1415	1-126-965-11	ELECT	22MF 20% 50V
C1416	1-126-933-11	ELECT	100MF 20% 16V
C1417	1-126-767-11	ELECT	1000MF 20% 16V
C1420	1-164-005-11	CERAMIC CHIP	0.47MF 25V

FILTER BLOCK

CM305 1-473-548-11 FILTER BLOCK, COMB
(KV-27S22/29RS22/29RS22C/29SD2/S9PS2)

CONNECTOR

CN270 1-573-298-11 CONNECTOR, BOARD TO BOARD 20P (KV-27S36)
 CN271 1-573-978-21 CONNECTOR, BOARD TO BOARD 11P (KV-27S36)
 CN351 * 1-564-509-11 PLUG, CONNECTOR 6P
 CN461 * 1-564-507-11 PLUG, CONNECTOR 4P
 CN501 * 1-580-798-11 CONNECTOR PIN (DY) 6P
 CN503 * 1-564-507-11 PLUG, CONNECTOR 4P
 CN1101 1-573-298-11 CONNECTOR, BOARD TO BOARD 20P (KV-27S36)
 CN1103 1-573-979-21 CONNECTOR, BOARD TO BOARD 11P
 CN1641* 1-564-515-11 PLUG, CONNECTOR 12P
 CN3001 1-573-298-11 CONNECTOR, BOARD TO BOARD 20P
(KV-27S26/27S36/29RS26/29RS26C)

DIODE

D001 8-719-991-33 DIODE 1SS133T-77
 D002 8-719-109-89 DIODE RD5 6ESB2
 D003 8-719-991-33 DIODE 1SS133T-77
 D004 8-719-110-17 DIODE RD10ESB2
 D005 8-719-991-33 DIODE 1SS133T-77
 D006 1-810-039-31 LED UNIT
 D011 8-719-983-14 DIODE MTZJ-T-77-3.9
 D013 8-719-991-33 DIODE 1SS133T-77
 D014 8-719-991-33 DIODE 1SS133T-77
 D015 8-719-991-33 DIODE 1SS133T-77
 D353 8-719-991-33 DIODE 1SS133T-77
 D356 8-719-991-33 DIODE 1SS133T-77
 D360 8-719-110-17 DIODE RD10ESB2
 D362 8-719-991-33 DIODE 1SS133T-77
 D368 8-719-991-33 DIODE 1SS133T-77 (KV-27S26/27S36/29RS26/29RS26C)
 D462 8-719-991-33 DIODE 1SS133T-77

REF.NO.	PART NO.	DESCRIPTION	REMARK
D501	8-719-109-89	DIODE RD5 6ESB2	
D502	8-719-945-80	DIODE ERC06-15S	
D503	8-719-945-80	DIODE ERC06-15S	
D504	8-719-900-26	DIODE ERD29-08J	
D505	8-719-908-03	DIODE GP08D	
D506	8-719-908-03	DIODE GP08D	
D507	8-719-991-33	DIODE 1SS133T-77	
D515	8-719-302-43	DIODE EL1Z	
D516	8-719-991-33	DIODE 1SS133T-77	
D518	8-719-991-33	DIODE 1SS133T-77	
D519 Δ	8-719-302-43	DIODE EL1Z	
D520	8-719-991-33	DIODE 1SS133T-77	
D521	8-719-921-63	DIODE MTZJ-7 5B	
D530	8-719-979-85	DIODE EGP20G	
D531	8-719-979-85	DIODE EGP20G	
D534	8-719-302-43	DIODE EL1Z	
D561	8-719-908-03	DIODE GP08D	
D562	8-719-991-33	DIODE 1SS133T-77	
D1102	8-719-982-24	DIODE MTZJ-33A	
D1103	8-719-109-89	DIODE RD5 6ESB2	
D1247	8-719-110-17	DIODE MTZJ-T-77-10B (EXCEPT KV-27S36)	
D1248	8-719-981-99	DIODE MTZJ-T-77-3 3	
D1261	8-719-110-17	DIODE MTZJ-T-77-10B (EXCEPT KV-27S36)	
D1262	8-719-110-17	DIODE MTZJ-T-77-10B (EXCEPT KV-27S36)	
D1263	8-719-110-17	DIODE RD10ESB2	
D1264	8-719-110-17	DIODE RD10ESB2	
<u>FERRITE BEAD</u>			
FB501	1-410-396-41	FERRITE BEAD INDUCTOR 0.45UH	
FB502	1-410-397-21	FERRITE BEAD INDUCTOR 1.1UH	
FB503	1-410-397-21	FERRITE BEAD INDUCTOR 1.1UH	
<u>IC</u>			
IC001	8-752-880-88	IC CXP85840-002S	
IC002	8-759-354-28	IC ST24C02FM6TR	
IC003	8-742-014-10	HYB IC SBX1981-51	
IC351	8-752-076-76	IC CXA2025AS	
IC461	8-759-980-43	IC TDA2009A	
IC501	8-759-700-07	IC NJM2903M	
IC561	8-759-980-58	IC TDA8172	
IC1001	8-752-058-68	IC CXA1315M (KV-27S26/27S36/29RS26/29RS26C)	
IC1261	8-759-366-77	IC MM1311AD (KV-27S22/29RS22/29RS22C/29SD2/29PS2)	
IC1261	8-759-366-78	IC MM1313AD (KV-27S26/29RS26/29RS26C)	
IC1401	8-759-369-39	IC BH3856FS-E2	
IC1402	8-759-100-96	IC UPC4558G2	



Note: The components identified by shading and mark Δ are critical for safety. Replace only with part number specified.

Note: Les composants identifiés par un trame et une marque Δ sont critiques pour la sécurité. Ne les remplacer que par une pièce portant le numéro spécifié.

REF.NO.	PART NO.	DESCRIPTION	REMARK
JACK			
J1232	1-774-749-11	JACK BLOCK, PIN 3P (KV-27S22/29RS22/29RS22C/29SD2/29PS2)	
J1232	1-774-751-11	TERMINAL BLOCK, S 3P (KV-27S26/29RS26/29RS26C)	
J1233	1-774-749-11	JACK BLOCK, PIN 3P (KV-27S26/29RS26/29RS26C)	
J1234	1-774-750-11	JACK BLOCK, PIN 2P (EXCEPT KV-26S36)	

CHIP CONDUCTOR

JR001	1-216-295-91	CONDUCTOR, CHIP (2012)	
JR163	1-216-295-91	CONDUCTOR, CHIP (2012)	
JR240	1-216-295-91	CONDUCTOR, CHIP (2012)	
JR351	1-216-295-91	CONDUCTOR, CHIP (2012) (KV-27S22/29RS22/29RS22C/29SD2/29PS2)	
JR352	1-216-295-91	CONDUCTOR, CHIP (2012) (KV-27S22/29RS22/29RS22C/29SD2/29PS2)	
JR501	1-216-295-91	CONDUCTOR, CHIP (2012)	
JR1264	1-216-295-91	CONDUCTOR, CHIP (2012) (KV-27S22/29RS22/29RS22C/29SD2/29PS2)	
JR1351	1-216-295-91	CONDUCTOR, CHIP (2012)	
JR1352	1-216-295-91	CONDUCTOR, CHIP (2012)	
JR4101	1-216-295-91	CONDUCTOR, CHIP (2012)	
JR4108	1-216-295-91	CONDUCTOR, CHIP (2012)	
JR4110	1-216-295-91	CONDUCTOR, CHIP (2012)	
JR4114	1-216-295-91	CONDUCTOR, CHIP (2012)	
JR4116	1-216-295-91	CONDUCTOR, CHIP (2012)	
JR4120	1-216-295-91	CONDUCTOR, CHIP (2012)	

COIL

L001	1-408-421-00	INDUCTOR	100UH
L002	1-408-421-00	INDUCTOR	100UH
L003	1-410-470-11	INDUCTOR	10UH
L004	1-410-470-11	INDUCTOR	10UH
L352	1-412-537-31	INDUCTOR	100UH
L461	1-408-408-00	INDUCTOR	8 2UH
L501 Δ	1-409-861-11	COIL, HORIZONTAL LINEARITY	
L502	1-412-552-11	INDUCTOR	2 2MMH
L503	1-406-677-11	COIL, CHOKE	10MMH
L511	1-406-607-11	COIL, CHOKE	15MMH
L517	1-412-552-11	INDUCTOR	2 2MMH
L1101	1-408-421-00	INDUCTOR	100UH
L1102	1-410-470-11	INDUCTOR	10UH
L1401	1-410-494-11	INDUCTOR	1MMH

IC LINK

PS461 Δ 1-532-984-11 LINK, IC 2A/90V

REF.NO.	PART NO.	DESCRIPTION	REMARK
TRANSISTOR			
Q001	8-729-216-22	TRANSISTOR 2SA1162-G	
Q002	8-729-422-27	TRANSISTOR 2SD601A-Q	
Q003	8-729-422-27	TRANSISTOR 2SD601A-Q	
Q004	8-729-216-22	TRANSISTOR 2SA1162-G	
Q010	8-729-422-27	TRANSISTOR 2SD601A-Q	
Q011	8-729-422-27	TRANSISTOR 2SD601A-Q	
Q012	8-729-422-27	TRANSISTOR 2SD601A-Q	
Q013	8-729-422-27	TRANSISTOR 2SD601A-Q	
Q014	8-729-422-27	TRANSISTOR 2SD601A-Q	
Q015	8-729-422-27	TRANSISTOR 2SD601A-Q	
Q016	8-729-422-27	TRANSISTOR 2SD601A-Q	
Q017	8-729-216-22	TRANSISTOR 2SA1162-G	
Q301	8-729-216-22	TRANSISTOR 2SA1162-G	
Q302	8-729-216-22	TRANSISTOR 2SA1162-G	
Q303	8-729-216-22	TRANSISTOR 2SA1162-G	
Q354	8-729-422-27	TRANSISTOR 2SD601A-Q	
Q356	8-729-216-22	TRANSISTOR 2SA1162-G	
Q358	8-729-422-27	TRANSISTOR 2SD601A-Q	
Q461	8-729-422-27	TRANSISTOR 2SD601A-Q	
Q462	8-729-216-22	TRANSISTOR 2SA1162-G	
Q501	8-729-140-50	TRANSISTOR 2SC3209LK	
Q502 Δ	8-729-016-32	TRANSISTOR 2SC4927-01	
Q511 Δ	8-729-422-27	TRANSISTOR 2SD601A-Q	
Q512 Δ	8-729-809-29	TRANSISTOR 2SC4159-E	
Q551	8-729-216-22	TRANSISTOR 2SA1162-G	
Q552	8-729-422-27	TRANSISTOR 2SD601A-Q	
Q561	8-729-422-27	TRANSISTOR 2SD601A-Q	
Q562	8-729-422-27	TRANSISTOR 2SD601A-Q	
Q563	8-729-105-08	TRANSISTOR 2SA1330-06	
Q1102	8-729-119-78	TRANSISTOR 2SC2785-HFE	
Q1103	8-729-422-27	TRANSISTOR 2SD601A-Q	
Q1231	8-729-422-27	TRANSISTOR 2SD601A-Q	
Q1232	8-729-422-27	TRANSISTOR 2SD601A-Q	
Q1261	8-729-216-22	TRANSISTOR 2SB709A-QRS-TX (EXCEPT KV-27S36)	
Q1262	8-729-216-22	TRANSISTOR 2SB709A-QRS-TX (EXCEPT KV-27S36)	
Q1263	8-729-422-27	TRANSISTOR 2SB709A-QRS-TX (EXCEPT KV-27S36)	

RESISTOR

R001	1-216-045-00	METAL GLAZE	680	5%	1/10W
R002	1-247-815-91	CARBON	220	5%	1/4W
R003	1-216-097-91	METAL GLAZE	100K	5%	1/10W
R004	1-216-121-91	METAL GLAZE	1M	5%	1/10W
R005	1-247-815-91	CARBON	220	5%	1/4W
R006	1-247-815-91	CARBON	220	5%	1/4W (KV-27S36)
R007	1-216-073-00	METAL GLAZE	10K	5%	1/10W
R008	1-247-815-91	CARBON	220	5%	1/4W (KV-27S36)

Note: The components identified by shading and mark Δ are critical for safety. Replace only with part number specified.

Note: Les composants identifiés par un trame et une marque Δ sont critiques pour la sécurité. Ne les remplacer que par une pièce portant le numéro spécifié.



REF.NO.	PART NO.	DESCRIPTION	REMARK
R009	1-216-073-00	METAL GLAZE	10K 5% 1/10W
R010	1-216-037-00	METAL GLAZE	330 5% 1/10W
R011	1-216-065-00	METAL GLAZE	4 7K 5% 1/10W
R012	1-216-033-00	METAL GLAZE	220 5% 1/10W
			(KV-27S26/27S36/29RS26/29RS26C)
R013	1-216-065-00	METAL GLAZE	4 7K 5% 1/10W
R014	1-216-065-00	METAL GLAZE	4 7K 5% 1/10W
R015	1-216-073-00	METAL GLAZE	10K 5% 1/10W
R016	1-216-073-00	METAL GLAZE	10K 5% 1/10W
R019	1-249-425-11	CARBON	4 7K 5% 1/4W
R020	1-216-065-00	METAL GLAZE	4 7K 5% 1/10W
R023	1-216-089-91	METAL GLAZE	47K 5% 1/10W
R025	1-163-010-11	CERAMIC CHIP	0 0012MF 10% 50V
R026	1-163-038-91	CERAMIC CHIP	0 1MF 25V
R028	1-249-417-11	CARBON	1K 5% 1/4W
R029	1-216-025-91	METAL GLAZE	100 5% 1/10W
R030	1-249-425-11	CARBON	4 7K 5% 1/4W
R031	1-247-815-91	CARBON	220 5% 1/4W
			(KV-27S36)
R032	1-247-815-91	CARBON	220 5% 1/4W
R034	1-247-815-91	CARBON	220 5% 1/4W
R035	1-247-815-91	CARBON	220 5% 1/4W
R036	1-216-049-91	METAL GLAZE	1K 5% 1/10W
R037	1-216-049-91	METAL GLAZE	1K 5% 1/10W
R038	1-216-049-91	METAL GLAZE	1K 5% 1/10W
R039	1-247-807-31	CARBON	100 5% 1/4W
R040	1-247-815-91	CARBON	220 5% 1/4W
			(KV-27S36)
R041	1-216-065-00	METAL GLAZE	4 7K 5% 1/10W
			(KV-27S36)
R042	1-216-065-00	METAL GLAZE	4 7K 5% 1/10W
			(KV-27S36)
R043	1-216-049-91	METAL GLAZE	1K 5% 1/10W
			(KV-27S36)
R044	1-216-049-91	METAL GLAZE	1K 5% 1/10W
R045	1-247-815-91	CARBON	220 5% 1/4W
			(KV-27S36)
R046	1-247-815-91	CARBON	220 5% 1/4W
R047	1-249-417-11	CARBON	1K 5% 1/4W
R048	1-249-417-11	CARBON	1K 5% 1/4W
R049	1-249-417-11	CARBON	1K 5% 1/4W
R050	1-247-815-91	CARBON	220 5% 1/4W
			(KV-27S36)
R051	1-247-815-91	CARBON	220 5% 1/4W
R052	1-216-061-00	METAL GLAZE	3 3K 5% 1/10W
R054	1-216-061-00	METAL GLAZE	3 3K 5% 1/10W
R055	1-216-097-91	METAL GLAZE	100K 5% 1/10W
R056	1-216-033-00	METAL GLAZE	220 5% 1/10W
R057	1-249-417-11	CARBON	1K 5% 1/4W
R058	1-216-033-00	METAL GLAZE	220 5% 1/10W

REF.NO.	PART NO.	DESCRIPTION	REMARK
R059	1-216-047-91	METAL GLAZE	820 5% 1/10W
R060	1-216-049-91	METAL GLAZE	1K 5% 1/10W
R061	1-216-055-00	METAL GLAZE	1 8K 5% 1/10W
R062	1-216-065-00	METAL GLAZE	4 7K 5% 1/10W
R063	1-216-073-00	METAL GLAZE	10K 5% 1/10W
R064	1-247-815-91	CARBON	220 5% 1/4W
R065	1-247-815-91	CARBON	220 5% 1/4W
R066	1-247-815-91	CARBON	220 5% 1/4W
R067	1-249-413-11	CARBON	470 5% 1/4W
R068	1-247-815-91	CARBON	220 5% 1/4W
R069	1-247-815-91	CARBON	220 5% 1/4W
R070	1-247-815-91	CARBON	220 5% 1/4W
R071	1-216-057-00	METAL GLAZE	2 2K 5% 1/10W
R072	1-216-033-00	METAL GLAZE	220 5% 1/10W
R073	1-216-033-00	METAL GLAZE	220 5% 1/10W
R074	1-216-033-00	METAL GLAZE	220 5% 1/10W
R075	1-216-033-00	METAL GLAZE	220 5% 1/10W
R076	1-216-033-00	METAL GLAZE	220 5% 1/10W
R077	1-216-033-00	METAL GLAZE	220 5% 1/10W
R078	1-249-417-11	CARBON	1K 5% 1/4W
R079	1-216-033-00	METAL GLAZE	220 5% 1/10W
R080	1-216-065-00	METAL GLAZE	4 7K 5% 1/10W
R081	1-216-025-91	METAL GLAZE	100 5% 1/10W
R082	1-216-025-91	METAL GLAZE	100 5% 1/10W
R083	1-249-429-11	CARBON	10K 5% 1/4W
R084	1-216-049-91	METAL GLAZE	1K 5% 1/10W
R087	1-247-815-91	CARBON	220 5% 1/4W
R090	1-216-033-00	METAL GLAZE	220 5% 1/10W
			(KV-27S36)
R092	1-249-429-11	CARBON	10K 5% 1/4W
R097	1-216-065-00	METAL GLAZE	4 7K 5% 1/10W
R099	1-216-065-00	METAL GLAZE	4 7K 5% 1/10W
R131	1-216-035-00	METAL GLAZE	270 5% 1/10W
R132	1-216-115-00	METAL GLAZE	560K 5% 1/10W
R133	1-216-039-00	METAL GLAZE	390 5% 1/10W
R135	1-216-073-00	METAL GLAZE	10K 5% 1/10W
R136	1-216-073-00	METAL GLAZE	10K 5% 1/10W
R137	1-216-033-00	METAL GLAZE	220 5% 1/10W
R311	1-216-295-01	CONDUCTOR CHIP (2012)	(EXCEPT KV-27S36)
R312	1-216-049-91	METAL GLAZE	1K 5% 1/10W
			(EXCEPT KV-27S36)
R313	1-216-295-91	CONDUCTOR CHIP (2012)	(EXCEPT KV-27S36)
R314	1-216-049-91	METAL GLAZE	1K 5% 1/10W
			(EXCEPT KV-27S36)
R353	1-208-786-11	METAL GLAZE	1 5K 0 50% 1/10W
R354	1-216-077-00	METAL GLAZE	15K 5% 1/10W
R355	1-216-033-00	METAL GLAZE	220 5% 1/10W
R356	1-216-033-00	METAL GLAZE	220 5% 1/10W
R358	1-247-815-91	CARBON	220 5% 1/4W

(KV-27S26/27S36/29RS26/29RS26C)

A

Note: The components identified by in this manual have been carefully factory-selected for each set in order to satisfy regulations regarding X-ray radiation. Should replacement be required, replace only with the value originally used.

Note:

The components identified by shading and mark Δ are critical for safety. Replace only with part number specified.

REF.NO.	PART NO.	DESCRIPTION	REMARK
R359	1-247-815-91	CARBON	220 5% 1/4W (KV-27S26/27S36/29RS26/29RS26C)
R360	1-247-815-91	CARBON	220 5% 1/4W (KV-27S26/27S36/29RS26/29RS26C)
R361	1-216-025-91	METAL GLAZE	100 5% 1/10W
R362	1-216-025-91	METAL GLAZE	100 5% 1/10W
R363	1-216-025-91	METAL GLAZE	100 5% 1/10W
R364	1-216-101-00	METAL GLAZE	150K 5% 1/10W
R365	1-216-101-00	METAL GLAZE	150K 5% 1/10W
R366	1-216-089-91	METAL GLAZE	47K 5% 1/10W
R367	1-216-097-91	METAL GLAZE	100K 5% 1/10W
R368	1-249-441-11	CARBON	100K 5% 1/4W
R369	1-216-097-91	METAL GLAZE	100K 5% 1/10W
R372	1-216-113-00	METAL GLAZE	470K 5% 1/10W
R373	1-216-073-00	METAL GLAZE	10K 5% 1/10W
R374	1-216-125-00	METAL GLAZE	1.5M 5% 1/10W
R375	1-216-025-91	METAL GLAZE	100 5% 1/10W
R376	1-216-073-00	METAL GLAZE	10K 5% 1/10W
R379	1-216-033-00	METAL GLAZE	220 5% 1/10W
R380	1-247-815-91	CARBON	220 5% 1/4W
R381	1-247-815-91	CARBON	220 5% 1/4W
R382	1-216-033-00	METAL GLAZE	220 5% 1/10W
R383	1-216-049-91	METAL GLAZE	1K 5% 1/10W
R384	1-216-109-00	METAL GLAZE	330K 5% 1/10W
R385	1-249-422-11	CARBON	2.7K 5% 1/4W
R386	1-216-049-91	METAL GLAZE	1K 5% 1/10W (KV-27S26/27S36/29RS26/29RS26C)
R387	1-216-049-91	METAL GLAZE	1K 5% 1/10W
R388	1-216-089-91	METAL GLAZE	47K 5% 1/10W
R389	1-216-067-00	METAL GLAZE	5.6K 5% 1/10W
R390	1-216-035-00	METAL GLAZE	270 5% 1/10W
R391	1-208-810-11	METAL GLAZE	15K 0.50% 1/10W
R392	1-216-025-91	METAL GLAZE	100 5% 1/10W
R393	1-216-043-91	METAL GLAZE	560 5% 1/10W
R394	1-216-059-00	METAL GLAZE	2.7K 5% 1/10W
R395	1-216-061-00	METAL GLAZE	3.3K 5% 1/10W
R397	1-249-425-11	CARBON	4.7K 5% 1/4W
R461	1-216-065-00	METAL GLAZE	4.7K 5% 1/10W
R462	1-216-089-91	METAL GLAZE	47K 5% 1/10W
R463	1-249-435-11	CARBON	33K 5% 1/4W
R464	1-216-097-91	METAL GLAZE	100K 5% 1/10W
R465	1-249-413-11	CARBON	470 5% 1/4W
R466	1-249-388-11	CARBON	3.9 5% 1/4W F
R467	1-216-069-00	METAL GLAZE	6.8K 5% 1/10W
R469	1-216-069-00	METAL GLAZE	6.8K 5% 1/10W
R471	1-216-069-00	METAL GLAZE	6.8K 5% 1/10W
R472	1-216-069-00	METAL GLAZE	6.8K 5% 1/10W
R473	1-249-398-11	CARBON	27 5% 1/4W
R475	1-249-430-11	CARBON	12K 5% 1/4W

REF.NO.	PART NO.	DESCRIPTION	REMARK
R476	1-249-430-11	CARBON	12K 5% 1/4W
R477	1-249-398-11	CARBON	27 5% 1/4W
R478	1-249-418-11	CARBON	1.2K 5% 1/4W F
R479	1-249-418-11	CARBON	1.2K 5% 1/4W F
R480	1-249-385-11	CARBON	2.2 5% 1/4W F
R481	1-249-385-11	CARBON	2.2 5% 1/4W F
R482	1-249-421-11	CARBON	2.2K 5% 1/4W
R483	1-249-421-11	CARBON	2.2K 5% 1/4W
R501	1-216-037-00	METAL GLAZE	330 5% 1/10W
R502	1-216-061-00	METAL GLAZE	3.3K 5% 1/10W
R503	1-249-426-11	CARBON	5.6K 5% 1/4W F
R504 Δ	1-215-918-00	METAL OXIDE	1.5K 5% 3W F
R505	1-249-431-11	CARBON	15K 5% 1/4W
R506	1-215-861-00	METAL OXIDE	47 5% 1W F
R507	1-249-401-11	CARBON	47 5% 1/4W
R508	1-249-427-11	CARBON	6.8K 5% 1/4W
R509	1-247-750-11	CARBON	680 5% 1/2W F
R510 Δ	1-215-860-11	METAL OXIDE	33 5% 1W F
R511 Δ	1-216-449-11	METAL OXIDE	56 5% 2W F
R512 Δ	1-216-450-00	METAL OXIDE	82 5% 2W F
R513	1-216-347-11	METAL OXIDE	0.68 5% 1W F
R515	1-216-083-00	METAL GLAZE	27K 5% 1/10W
R516	1-216-057-00	METAL GLAZE	2.2K 5% 1/10W
R517	1-249-415-11	CARBON	680 5% 1/4W
R518	1-216-073-00	METAL GLAZE	10K 5% 1/10W
R519	1-249-411-11	CARBON	330 5% 1/4W
R523	1-216-073-00	METAL GLAZE	10K 5% 1/10W
R524	1-249-429-11	CARBON	10K 5% 1/4W
R525	1-216-071-00	METAL GLAZE	8.2K 5% 1/10W
R528	1-216-081-00	METAL GLAZE	22K 5% 1/10W
R529	1-208-814-11	METAL GLAZE	22K 0.50% 1/10W
<input checked="" type="checkbox"/> R530 Δ	1-216-065-00	METAL GLAZE	4.7K 5% 1/10W
<input checked="" type="checkbox"/> R531 Δ	1-216-065-00	METAL GLAZE	4.7K 5% 1/10W
R532	1-208-760-11	METAL GLAZE	120 0.50% 1/10W
R533 Δ	1-215-902-11	METAL OXIDE	47K 5% 1W F
R535	1-216-101-00	METAL GLAZE	150K 5% 1/10W
R536 Δ	1-260-288-11	CARBON	0.47 5% 1/2W
R537 Δ	1-260-288-11	CARBON	0.47 5% 1/2W
R538	1-247-887-00	CARBON	220K 5% 1/4W
R543	1-249-377-11	CARBON	0.47 5% 1/4W F
R546	1-215-456-00	METAL	30K 1% 1/4W
R547	1-215-457-00	METAL	33K 1% 1/4W
R549	1-215-437-00	METAL	4.7K 1% 1/4W
R550 Δ	1-249-377-11	CARBON	0.47 5% 1/4W F
R551	1-215-873-00	METAL OXIDE	4.7K 5% 1W F
R552	1-216-069-00	METAL GLAZE	6.8K 5% 1/10W
R553 Δ	1-249-377-11	CARBON	0.47 5% 1/4W F
R554	1-216-057-00	METAL GLAZE	2.2K 5% 1/10W
R561	1-216-073-00	METAL GLAZE	10K 5% 1/10W

Note: The components identified by shading and mark Δ are critical for safety. Replace only with part number specified.

Note: Les composants identifiés par un trame et une marque Δ sont critiques pour la sécurité. Ne les remplacer que par une pièce portant le numéro spécifique.



REF.NO.	PART NO.	DESCRIPTION	REMARK
R563	Δ 1-216-351-00	METAL OXIDE	1.5 5% 1W F
R564	1-249-392-11	CARBON	8 2 5% 1/4W
R565	Δ 1-215-890-11	METAL OXIDE	470 5% 2W F
R566	1-216-073-00	METAL GLAZE	10K 5% 1/10W
R567	Δ 1-249-385-11	CARBON	2.2 5% 1/4W F
R568	1-216-073-00	METAL GLAZE	10K 5% 1/10W
R569	1-216-073-00	METAL GLAZE	10K 5% 1/10W
R570	1-216-097-91	METAL GLAZE	100K 5% 1/10W
R571	1-216-081-00	METAL GLAZE	22K 5% 1/10W
R572	1-216-081-00	METAL GLAZE	22K 5% 1/10W
R573	1-216-097-91	METAL GLAZE	100K 5% 1/10W
R574	Δ 1-216-365-00	METAL OXIDE	0.47 5% 2W F
R575	1-216-113-00	METAL GLAZE	470K 5% 1/10W
R576	1-216-073-00	METAL GLAZE	10K 5% 1/10W
R577	1-216-097-91	METAL GLAZE	100K 5% 1/10W
R578	1-208-784-11	METAL GLAZE	1 2K 0 50% 1/10W
R579	1-208-842-11	METAL GLAZE	330K 0 50% 1/10W
R580	1-249-441-11	CARBON	100K 5% 1/4W
R1001	1-247-807-31	CARBON	100 5% 1/4W (KV-27S26/27S36/29RS26/29RS26C)
R1002	1-247-807-31	CARBON	100 5% 1/4W (KV-27S26/27S36/29RS26/29RS26C)
R1005	1-216-073-00	METAL GLAZE	10K 5% 1/10W (KV-27S26/27S36/29RS26/29RS26C)
R1009	1-216-033-00	METAL GLAZE	220 5% 1/10W
R1010	1-216-033-00	METAL GLAZE	220 5% 1/10W
R1101	1-216-049-91	METAL GLAZE	1K 5% 1/10W
R1102	1-215-900-11	METAL OXIDE	22K 5% 2W F
R1103	1-216-051-00	METAL GLAZE	1 2K 5% 1/10W
R1104	1-216-083-00	METAL GLAZE	27K 5% 1/10W
R1105	1-216-689-11	METAL GLAZE	39K 5% 1/10W
R1106	1-216-049-91	METAL GLAZE	1K 5% 1/10W
R1107	1-216-065-00	METAL GLAZE	4 7K 5% 1/10W
R1108	1-216-073-00	METAL GLAZE	10K 5% 1/10W
R1109	1-216-019-00	METAL GLAZE	56 5% 1/10W
R1110	1-216-019-00	METAL GLAZE	56 5% 1/10W
R1111	1-216-019-00	METAL GLAZE	56 5% 1/10W
R1115	1-216-045-00	METAL GLAZE	680 5% 1/10W
R1117	1-249-425-11	CARBON	4 7K 5% 1/4W
R1118	1-249-425-11	CARBON	4 7K 5% 1/4W
R1120	1-216-057-00	METAL GLAZE	2 2K 5% 1/10W
R1121	1-216-035-00	METAL GLAZE	270 5% 1/10W
R1122	1-216-115-00	METAL GLAZE	560K 5% 1/10W
R1123	1-216-039-00	METAL GLAZE	390 5% 1/10W
R1125	1-216-057-00	METAL GLAZE	2 2K 5% 1/10W
R1126	1-216-035-00	METAL GLAZE	270 5% 1/10W
R1127	1-216-115-00	METAL GLAZE	560K 5% 1/10W
R1128	1-216-039-00	METAL GLAZE	390 5% 1/10W
R1130	1-216-057-00	METAL GLAZE	2 2K 5% 1/10W

REF.NO.	PART NO.	DESCRIPTION	REMARK
R1234	1-249-441-11	CARBON	100K 5% 1/4W (EXCEPT KV-27S36)
R1240	1-216-022-00	METAL GLAZE	75 5% 1/10W (KV-27S26/27S36/29RS26/29RS26C)
R1241	1-216-022-00	METAL GLAZE	75 5% 1/10W (KV-27S26/27S36/29RS26/29RS26C)
R1242	1-216-065-00	METAL GLAZE	4 7K 5% 1/10W (KV-27S26/27S36/29RS26/29RS26C)
R1243	1-249-441-11	CARBON	100K 5% 1/4W (EXCEPT KV-27S36)
R1244	1-216-022-00	METAL GLAZE	75 5% 1/10W (EXCEPT KV-27S36)
R1245	1-216-113-00	METAL GLAZE	470K 5% 1/10W (EXCEPT KV-27S36)
R1246	1-216-065-00	METAL GLAZE	4 7K 5% 1/10W (EXCEPT KV-27S36)
R1247	1-216-113-00	METAL GLAZE	470K 5% 1/10W (EXCEPT KV-27S36)
R1248	1-216-065-00	METAL GLAZE	4 7K 5% 1/10W (EXCEPT KV-27S36)
R1249	1-216-022-00	METAL GLAZE	75 5% 1/10W (EXCEPT KV-27S36)
R1250	1-216-113-00	METAL GLAZE	470K 5% 1/10W (KV-27S26/29RS26/29RS26C)
R1251	1-216-065-00	METAL GLAZE	4 7K 5% 1/10W (KV-27S26/29RS26/29RS26C)
R1252	1-216-113-00	METAL GLAZE	470K 5% 1/10W (KV-27S26/29RS26/29RS26C)
R1253	1-216-065-00	METAL GLAZE	4 7K 5% 1/10W (KV-27S26/29RS26/29RS26C)
R1254	1-216-113-00	METAL GLAZE	470K 5% 1/10W (KV-27S26/29RS26/29RS26C)
R1255	1-216-049-91	METAL GLAZE	1K 5% 1/10W (EXCEPT KV-27S36)
R1255	1-216-295-91	CONDUCTOR, CHIP	(2012) (KV-27S36)
R1256	1-216-113-00	METAL GLAZE	470K 5% 1/10W (EXCEPT KV-27S36)
R1257	1-216-049-91	METAL GLAZE	1K 5% 1/10W (EXCEPT KV-27S36)
R1258	1-216-061-00	METAL GLAZE	3 3K 5% 1/10W
R1259	1-216-097-91	METAL GLAZE	100K 5% 1/10W
R1260	1-216-061-00	METAL GLAZE	3 3K 5% 1/10W
R1261	1-216-033-00	METAL GLAZE	220 5% 1/10W (EXCEPT KV-27S36)
R1262	1-216-025-91	METAL GLAZE	220 5% 1/10W (EXCEPT KV-27S36)
R1263	1-216-033-00	METAL GLAZE	220 5% 1/10W (KV-27S26/29RS26/29RS26C)
R1264	1-216-025-91	METAL GLAZE	100 5% 1/10W (EXCEPT KV-27S36)
R1265	1-216-033-00	METAL GLAZE	220 5% 1/10W (KV-27S26/29RS26/29RS26C)
R1266	1-216-025-91	METAL GLAZE	100 5% 1/10W (EXCEPT KV-27S36)



Note. The components identified by shading and mark Δ are critical for safety. Replace only with part number specified.

Note. Les composants identifiés par un trame et une marque Δ sont critiques pour la sécurité. Ne les remplacer que par une pièce portant le numéro spécifié.

REF NO	PART NO	DESCRIPTION	REMARK
R1272	1-216-025-91	METAL GLAZE (KV-27S22/29RS22/29RS22C/29SD2/29PS2)	100 5% 1/10W
R1273	1-216-033-00	METAL GLAZE (KV-27S26/29RS26/29RS26C)	220 5% 1/10W
R1274	1-216-025-91	METAL GLAZE (KV-27S26/29RS26/29RS26C)	100 5% 1/10W
R1277	1-247-815-91	CARBON (EXCEPT KV-27S36)	220 5% 1/4W
R1278	1-247-815-91	CARBON (EXCEPT KV-27S36)	220 5% 1/4W
R1280	1-216-025-91	METAL GLAZE (EXCEPT KV-27S36)	100 5% 1/10W
R1282	1-216-025-91	METAL GLAZE (EXCEPT KV-27S36)	100 5% 1/10W
R1283	1-247-791-91	CARBON (KV-27S26/29RS26/29RS26C)	22 5% 1/4W
R1284	1-247-807-31	CARBON (EXCEPT KV-27S36)	100 5% 1/4W
R1286	1-216-049-91	METAL GLAZE (EXCEPT KV-27S36)	1K 5% 1/10W
R1287	1-216-049-91	METAL GLAZE (EXCEPT KV-27S36)	1K 5% 1/10W
R1288	1-247-807-31	CARBON (EXCEPT KV-27S36)	100 5% 1/4W
R1290	1-216-041-00	METAL GLAZE (EXCEPT KV-27S36)	470 5% 1/10W
R1291	1-216-045-00	METAL GLAZE (EXCEPT KV-27S36)	680 5% 1/10W
R1292	1-216-065-00	METAL GLAZE (EXCEPT KV-27S36)	4.7K 5% 1/10W
R1293	1-216-065-00	METAL GLAZE (EXCEPT KV-27S36)	4.7K 5% 1/10W
R1294	1-216-049-91	METAL GLAZE	1K 5% 1/10W
R1295	1-216-049-91	METAL GLAZE	1K 5% 1/10W
R1296	1-216-025-91	METAL GLAZE (KV-27S22/29RS22/29RS22C/29SD2/29PS2)	100 5% 1/10W
R1297	1-216-025-91	METAL GLAZE (KV-27S26/29RS26/29RS26C)	100 5% 1/10W
R1351	1-247-815-91	CARBON	220 5% 1/4W
R1352	1-247-815-91	CARBON	220 5% 1/4W
R1353	1-247-815-91	CARBON	220 5% 1/4W
R1354	1-216-033-00	METAL GLAZE	220 5% 1/10W
R1355	1-216-025-91	METAL GLAZE	100 5% 1/10W
R1356	1-216-025-91	METAL GLAZE	100 5% 1/10W
R1357	1-216-025-91	METAL GLAZE	100 5% 1/10W
R1358	1-247-807-31	CARBON	100 5% 1/4W
R1359	1-216-025-91	METAL GLAZE	100 5% 1/10W
R1360	1-216-069-00	METAL GLAZE	6.8K 5% 1/10W
R1361	1-216-065-00	METAL GLAZE	4.7K 5% 1/10W
R1362	1-216-295-91	CONDUCTOR, CHIP (2012)	
R1402	1-249-429-11	CARBON (EXCEPT KV-27S36)	10K 5% 1/4W

REF.NO.	PART NO.	DESCRIPTION	REMARK
R1404	1-249-429-11	CARBON	10K 5% 1/4W (EXCEPT KV-27S36)
R1407	1-216-073-00	METAL GLAZE	10K 5% 1/10W
R1408	1-249-429-11	CARBON	10K 5% 1/4W
R1409	1-249-429-11	CARBON	10K 5% 1/4W (KV-27S36)
R1411	1-216-073-00	METAL GLAZE	10K 5% 1/10W
R1412	1-216-081-00	METAL GLAZE	22K 5% 1/10W
R1413	1-216-089-91	METAL GLAZE	47K 5% 1/10W
R1414	1-216-089-91	METAL GLAZE	47K 5% 1/10W
R1415	1-216-025-91	METAL GLAZE	100 5% 1/10W
R1418	1-216-081-00	METAL GLAZE	22K 5% 1/10W
R1419	1-216-089-91	METAL GLAZE	47K 5% 1/10W
R1420	1-216-089-91	METAL GLAZE	47K 5% 1/10W
R1421	1-216-025-91	METAL GLAZE	100 5% 1/10W
R1424	1-247-807-31	CARBON	100 5% 1/4W
R1425	1-247-807-31	CARBON	100 5% 1/4W

SWITCH

S001	1-692-431-21	SWITCH, TACTILE
S002	1-692-431-21	SWITCH, TACTILE
S003	1-692-431-21	SWITCH, TACTILE
S004	1-692-431-21	SWITCH, TACTILE
S005	1-692-431-21	SWITCH, TACTILE
S006	1-692-431-21	SWITCH, TACTILE
S007	1-692-431-21	SWITCH, TACTILE
S501	1-572-707-11	SWITCH, LEVER

TRANSFORMER

T501	1-437-210-11	TRANSFORMER, HORIZONTAL DRIVE
T502 Δ	1-424-545-11	TRANSFORMER, FERRITE (PMT)
T503 Δ	1-453-207-11	TRANSFORMER ASSY, FLYBACK (NX-2609//X4C)

TUNER

TU102 Δ	8-598-340-00	TUNER BTF-WA404
----------------	--------------	-----------------

CRYSTAL

X001	1-578-774-11	VIBRATOR, CRYSTAL
X353	1-567-505-11	OSCILLATOR, CRYSTAL
X354	1-577-611-11	OSCILLATOR, CERAMIC



Note: The components identified by shading and mark Δ are critical for safety. Replace only with part number specified.

Note: Les composants identifiés par un trame et une marque Δ sont critiques pour la sécurité. Ne les remplacer que par une pièce portant le numéro spécifique.

REF.NO.	PART NO	DESCRIPTION	REMARK
<u>IC</u>			
IC641	8-749-920-58	IC SI-3090CA	
IC642	8-759-701-56	IC NJM78M05FA	
IC643	8-749-012-13	IC DM-58	
<u>COIL</u>			
L642	1-412-529-11	INDUCTOR	22UH
L643	1-412-525-31	INDUCTOR	10UH
<u>TRANSISTOR</u>			
Q601 Δ	8-729-019-49	TRANSISTOR 2SC4834MNP	(EXCEPT KV-29RS22C/29RS26C)
Q601 Δ	8-729-019-50	TRANSISTOR 2SC4834NP (KV-29RS22C/29RS26C)	
Q602 Δ	8-729-019-49	TRANSISTOR 2SC4834MNP	(EXCEPT KV-29RS22C/29RS26C)
Q602 Δ	8-729-019-50	TRANSISTOR 2SC4834NP (KV-29RS22C/29RS26C)	
Q644	8-729-119-78	TRANSISTOR 2SC2785-HFE	
Q645	8-729-119-76	TRANSISTOR 2SA1175-HFE	
Q646	8-729-119-78	TRANSISTOR 2SC2785-HFE	(EXCEPT KV-29RS22C/29RS26C)
<u>RESISTOR</u>			
R603 Δ	1-219-776-11	CARBON	2.2M 10% 1/2W (EXCEPT KV-29RS22C/29RS26C)
R603 Δ	1-247-289-00	CARBON	8.2M 5% 1W (KV-29RS22C/29RS26C)
R605	1-247-893-11	CARBON	390K 5% 1/4W
R606	1-247-893-11	CARBON	390K 5% 1/4W
R607 Δ	1-202-933-61	FUSIBLE	0.1 10% 1/2W F
R608 Δ	1-216-369-00	METAL OXIDE	1 5% 2W F (KV-29RS22C/29RS26C)
R608 Δ	1-216-372-11	METAL OXIDE	1.8 5% 2W F (EXCEPT KV-29RS22C/29RS26C)
R609	1-247-791-91	CARBON	22 5% 1/4W
R610	1-247-791-91	CARBON	22 5% 1/4W
R611 Δ	1-216-369-00	METAL OXIDE	1 5% 2W F (KV-29RS22C/29RS26C)
R611 Δ	1-216-372-11	METAL OXIDE	1.8 5% 2W F (EXCEPT KV-29RS22C/29RS26C)
R612	1-247-887-00	CARBON	220K 5% 1/4W
R613	1-247-887-00	CARBON	220K 5% 1/4W
R614	1-247-887-00	CARBON	220K 5% 1/4W
R615	1-247-887-00	CARBON	220K 5% 1/4W
R616	1-247-791-91	CARBON	22 5% 1/4W
R617	1-247-791-91	CARBON	22 5% 1/4W
R622 Δ	1-212-958-00	FUSIBLE	10 5% 1/2W F
R623 Δ	1-243-032-11	WIREBOUND	3.9 5% 20W (KV-29RS22C/29RS26C)
R623 Δ	1-205-943-11	WIREWOUND	1 5% 20W (EXCEPT KV-29RS22C/29RS26C)

REF.NO.	PART NO	DESCRIPTION	REMARK
R641	1-247-843-11	CARBON	33K 5% 1/4W
R642	1-247-843-11	CARBON	33K 5% 1/4W
R643	1-249-387-11	CARBON	33 5% 1/4W F
R644 Δ	1-215-882-00	METAL OXIDE	22 5% 2W F
R645 Δ	1-260-304-51	CARBON	10 5% 1/2W (KV-29RS22C/29RS26C)
R646	1-216-369-00	METAL OXIDE	1 55 2W F (KV-27S26/27S22/29RS26/29PS2/29SD2/29RS22)
R647	1-249-417-11	CARBON	1K 5% 1/4W
R648	1-247-887-00	CARBON	220K 5% 1/4W
R649	1-249-425-11	CARBON	4.7K 5% 1/4W F
R652	1-249-421-11	CARBON	2.2K 5% 1/4W
R659	1-249-429-11	CARBON	10K 5% 1/4W (KV-29RS22C/29RS26C)
R661	1-249-413-11	CARBON	470 5% 1/4W F
R662	1-249-429-11	CARBON	10K 5% 1/4W
R663 Δ	1-249-377-11	CARBON	0.47 5% 1/4W F
R664 Δ	1-249-377-11	CARBON	0.47 5% 1/4W F
R665 Δ	1-249-377-11	CARBON	0.47 5% 1/4W F
R666 Δ	1-249-377-11	CARBON	0.47 5% 1/4W F
R667 Δ	1-249-377-11	CARBON	0.47 5% 1/4W F
R668 Δ	1-249-377-11	CARBON	0.47 5% 1/4W F
R670 Δ	1-249-377-11	CARBON	0.47 5% 1/4W F
R671 Δ	1-249-377-11	CARBON	0.47 5% 1/4W F
R672 Δ	1-249-377-11	CARBON	0.47 5% 1/4W F
R678	1-247-863-91	CARBON	22K 5% 1/4W (EXCEPT KV-29RS22C/29RS26C)
R679	1-247-863-91	CARBON	22K 5% 1/4W (EXCEPT KV-29RS22C/29RS26C)
R680	1-249-429-11	CARBON	10K 5% 1/4W (EXCEPT KV-29RS22C/29RS26C)
R681	1-249-407-11	CARBON	150 5% 1/4W (EXCEPT KV-29RS22C/29RS26C)
<u>RELAY</u>			
RY601 Δ	1-755-018-11	RELAY (EXCEPT KV-27S36)	
RY601 Δ	1-755-146-11	RELAY (KV-27S36)	
<u>TRANSFORMER</u>			
T601 Δ	1-426-717-11	TRANSFORMER, LINE FILTER (LFT)	(KV-27S26/27S22/27S36)
T602 Δ	1-424-220-11	TRANSFORMER, LINE FILTER	(KV-27S26/27S22/27S36)
T602 Δ	1-426-717-11	TRANSFORMER, LINE FILTER (LFT)	(KV-29RS26/29PS2/29SD2/29RS22/29RS22C/29RS26C)
T603 Δ	1-427-864-11	TRANSFORMER, CONVERTER (PRT)	
T605 Δ	1-429-415-11	TRANSFORMER, CONVERTER (PIT)	

Note: The components identified by shading and mark Δ are critical for safety. Replace only with part number specified.

Note: Les composants identifiés par un trame et une marque Δ sont critiques pour la sécurité. Ne les remplacer que par une pièce portant le numéro spécifique.



REF. NO.	PART NO.	DESCRIPTION	REMARK
<u>THERMISTOR</u>			
THP601	Δ 1-809-539-21	THERMISTOR, POSITIVE	(EXCEPT KV-29RS26C/9RS22C)
THP601	Δ 1-809-827-11	THERMISTOR, POSITIVE (KV-29RS26C/9RS22C)	

<u>VARISTOR</u>			
VDR601	1-810-974-21	VARISTOR	



- * A-1331-549-A C BOARD, MOUNTED
- 4-382-854-11 SCREW (M3X10), P, SW (+)

<u>CAPACITOR</u>					
C1765	1-102-116-00	CERAMIC	680PF	10%	50V
C1766	1-102-117-00	CERAMIC	820PF	10%	50V
C1767	1-102-116-00	CERAMIC	680PF	10%	50V
C1775	1-102-116-00	CERAMIC	680PF	10%	50V
C1776	1-102-117-00	CERAMIC	820PF	10%	50V
C1777	1-102-116-00	CERAMIC	680PF	10%	50V
C1785	1-102-116-00	CERAMIC	680PF	10%	50V
C1786	1-102-117-00	CERAMIC	820PF	10%	50V
C1787	1-102-116-00	CERAMIC	680PF	10%	50V
C1790	1-102-129-00	CERAMIC	0 01MF	10%	50V
C1791	1-126-933-11	ELECT	100MF	20%	16V
C1793	1-107-651-11	ELECT	4.7MF	20%	250V
C1795	1-102-074-00	CERAMIC	0 001MF	10%	50V
C1797	1-106-375-12	MYLAR	0 022MF	99%	200V
C1798	1-106-375-12	MYLAR	0.022MF	99%	200V
C1799	1-162-114-00	CERAMIC	0 0047MF		2KV

<u>CONNECTOR</u>			
CN1761*	1-564-509-11	PLUG, CONNECTOR 6P	
CN1764*	1-564-507-11	PLUG, CONNECTOR 4P	
CN1765	1-695-915-11	TAB (CONTACT)	
CN1766	1-695-915-11	TAB (CONTACT)	

<u>DIODE</u>			
D1761	8-719-991-33	DIODE 1SS133T-77	
D1762	8-719-991-33	DIODE 1SS133T-77	
D1763	8-719-991-33	DIODE 1SS133T-77	
D1771	8-719-991-33	DIODE 1SS133T-77	
D1772	8-719-991-33	DIODE 1SS133T-77	
D1773	8-719-991-33	DIODE 1SS133T-77	
D1781	8-719-991-33	DIODE 1SS133T-77	
D1782	8-719-991-33	DIODE 1SS133T-77	

REF. NO.	PART NO.	DESCRIPTION	REMARK
D1783	8-719-991-33	DIODE 1SS133T-77	
D1790	8-719-991-33	DIODE 1SS133T-77	
D1792	8-719-983-14	DIODE MTZJ-T-77-3 9	

<u>JACK</u>			
J1761	Δ 1-251-388-11	SOCKET, CRT	

<u>COIL</u>			
L1790	1-410-667-31	INDUCTOR	22UH

<u>TRANSISTOR</u>			
Q1761	8-729-119-78	TRANSISTOR 2SC2785-HFE	
Q1762	8-729-326-11	TRANSISTOR 2SC2611	
Q1763	8-729-200-17	TRANSISTOR 2SA1091-O	
Q1771	8-729-119-78	TRANSISTOR 2SC2785-HFE	
Q1772	8-729-326-11	TRANSISTOR 2SC2611	
Q1773	8-729-200-17	TRANSISTOR 2SA1091-O	
Q1781	8-729-119-78	TRANSISTOR 2SC2785-HFE	
Q1782	8-729-326-11	TRANSISTOR 2SC2611	
Q1783	8-729-200-17	TRANSISTOR 2SA1091-O	
Q1790	8-729-119-76	TRANSISTOR 2SA1175-HFE	

<u>RESISTOR</u>					
R1760	1-260-105-11	CARBON	3.3K	5%	1/2W
R1761	1-247-807-31	CARBON	100	5%	1/4W
R1763	1-249-409-11	CARBON	220	5%	1/4W F
R1764	Δ 1-216-486-00	METAL OXIDE	8.2K	5%	3W F
R1765	1-249-411-11	CARBON	330	5%	1/4W
R1766	1-249-393-11	CARBON	10	5%	1/4W
R1767	1-249-429-11	CARBON	10K	5%	1/4W
R1768	1-249-411-11	CARBON	330	5%	1/4W
R1770	1-260-105-11	CARBON	3 3K	5%	1/2W
R1771	1-247-807-31	CARBON	100	5%	1/4W

R1773	1-249-409-11	CARBON	220	5%	1/4W F
R1774	Δ 1-216-486-00	METAL OXIDE	8 2K	5%	3W F
R1775	1-249-407-11	CARBON	150	5%	1/4W
R1776	1-249-393-11	CARBON	10	5%	1/4W
R1777	1-249-429-11	CARBON	10K	5%	1/4W
R1780	1-260-105-11	CARBON	3 3K	5%	1/2W
R1781	1-247-807-31	CARBON	100	5%	1/4W
R1783	1-249-409-11	CARBON	220	5%	1/4W F
R1784	Δ 1-216-486-00	METAL OXIDE	8 2K	5%	3W F
R1785	1-249-407-11	CARBON	150	5%	1/4W
R1786	1-249-393-11	CARBON	10	5%	1/4W
R1787	1-249-429-11	CARBON	10K	5%	1/4W
R1789	1-249-437-11	CARBON	47K	5%	1/4W
R1792	1-247-815-91	CARBON	220	5%	1/4W
R1793	1-247-863-91	CARBON	22K	5%	1/4W



Note: The components identified by shading and mark Δ are critical for safety. Replace only with part number specified.

Note: Les composants identifiés par un trame et une marque Δ sont critiques pour la sécurité. Ne les remplacer que par une pièce portant le numéro spécifique.

REF.NO.	PART NO.	DESCRIPTION	REMARK
R1794	1-249-417-11	CARBON	1K 5% 1/4W
R1795	1-260-087-11	CARBON	100 5% 1/2W
R1796 Δ	1-216-374-00	METAL OXIDE	2.7 5% 2W F
R1797	1-260-123-11	CARBON	100K 5% 1/2W



* A-1390-585-A SC BOARD, MOUNTED (KV-27S36 ONLY)

CONNECTOR

CN104	1-573-978-21	CONNECTOR, BOARD TO BOARD 11P
CN105	1-573-978-21	CONNECTOR, BOARD TO BOARD 11P



* A-1394-863-A UV BOARD, COMPLETE (KV-27S36 ONLY)

CAPACITOR

C231	1-163-031-11	CERAMIC CHIP	0 01MF	50V
C232	1-136-161-00	FILM	0 047MF	5% 50V
C233	1-136-161-00	FILM	0 047MF	5% 50V
C234	1-126-960-11	ELECT	1MF	20% 50V
C235	1-126-960-11	ELECT	1MF	20% 50V
C236	1-136-161-00	FILM	0 047MF	5% 50V
C237	1-126-960-11	ELECT	1MF	20% 50V
C238	1-126-960-11	ELECT	1MF	20% 50V
C261	1-136-161-00	FILM	0 047MF	5% 50V
C262	1-104-664-11	ELECT	47MF	20% 25V
C263	1-136-161-00	FILM	0 047MF	5% 50V
C264	1-126-941-11	ELECT	470MF	20% 25V
C265	1-104-664-11	ELECT	47MF	20% 25V
C266	1-126-960-11	ELECT	1MF	20% 50V
C267	1-126-960-11	ELECT	1MF	20% 50V
C270	1-126-960-11	ELECT	1MF	20% 50V
C271	1-126-960-11	ELECT	1MF	20% 50V
C273	1-136-165-00	FILM	0.1MF	5% 50V
C274	1-163-031-11	CERAMIC CHIP	0 01MF	50V
C276	1-163-251-11	CERAMIC CHIP	100PF	5% 50V
C301	1-126-935-11	ELECT	470MF	20% 16V

FILTER BLOCK

CM301	1-467-554-21	FILTER BLOCK, COMB
-------	--------------	--------------------

CONNECTOR

CN261	1-573-979-21	CONNECTOR, BOARD TO BOARD 11P
CN262	1-573-301-21	CONNECTOR, BOARD TO BOARD 20P
CN263 *	1-564-506-11	PLUG, CONNECTOR 3P

REF.NO.	PART NO.	DESCRIPTION	REMARK
CN264	1-573-979-21	CONNECTOR, BOARD TO BOARD 11P	
		<u>DIODE</u>	

D231	8-719-110-17	DIODE RD10ESB2
D232	8-719-110-17	DIODE RD10ESB2
D233	8-719-110-17	DIODE RD10ESB2
D234	8-719-110-17	DIODE RD10ESB2
D235	8-719-110-17	DIODE RD10ESB2

D236	8-719-110-17	DIODE RD10ESB2
D240	8-719-110-17	DIODE RD10ESB2
D241	8-719-110-17	DIODE RD10ESB2
D242	8-719-110-17	DIODE RD10ESB2
D243	8-719-110-17	DIODE RD10ESB2

D244	8-719-110-17	DIODE RD10ESB2
D264	8-719-110-17	DIODE RD10ESB2
D265	8-719-110-17	DIODE RD10ESB2

IC

IC261	8-759-366-78	IC MM1313AD
-------	--------------	-------------

JACK

J231	1-750-515-11	TERMINAL BLOCK, S 3P
J232	1-774-746-11	JACK BLOCK, PIN
J233	1-774-747-11	JACK BLOCK, PIN

CHIP CONDUCTOR

JR151	1-216-295-91	CONDUCTOR, CHIP (2012)
JR152	1-216-295-91	CONDUCTOR, CHIP (2012)
JR201	1-216-295-91	CONDUCTOR, CHIP (2012)
JR204	1-216-295-91	CONDUCTOR, CHIP (2012)
JR205	1-216-295-91	CONDUCTOR, CHIP (2012)
JR206	1-216-295-91	CONDUCTOR, CHIP (2012)
JR208	1-216-295-91	CONDUCTOR, CHIP (2012)
JR209	1-216-295-91	CONDUCTOR, CHIP (2012)
JR210	1-216-295-91	CONDUCTOR, CHIP (2012)
JR211	1-216-295-91	CONDUCTOR, CHIP (2012)
JR212	1-216-295-91	CONDUCTOR, CHIP (2012)
JR213	1-216-295-91	CONDUCTOR, CHIP (2012)
JR214	1-216-295-91	CONDUCTOR, CHIP (2012)
JR215	1-216-295-91	CONDUCTOR, CHIP (2012)
JR216	1-216-295-91	CONDUCTOR, CHIP (2012)
JR217	1-216-295-91	CONDUCTOR, CHIP (2012)
JR218	1-216-295-91	CONDUCTOR, CHIP (2012)
JR219	1-216-295-91	CONDUCTOR, CHIP (2012)
JR220	1-216-295-91	CONDUCTOR, CHIP (2012)
JR221	1-216-295-91	CONDUCTOR, CHIP (2012)
JR222	1-216-295-91	CONDUCTOR, CHIP (2012)
JR223	1-216-295-91	CONDUCTOR, CHIP (2012)

Note: The components identified by shading and mark Δ are critical for safety. Replace only with part number specified.

Note: Les composants identifiés par un trame et une marque Δ sont critiques pour la sécurité. Ne les remplacer que par une pièce portant le numéro spécifique.

UV

REF.NO.	PART NO.	DESCRIPTION	REMARK
JR226	1-216-295-91	CONDUCTOR, CHIP (2012)	
JR228	1-216-295-91	CONDUCTOR, CHIP (2012)	
JR261	1-216-295-91	CONDUCTOR, CHIP (2012)	
JR262	1-216-295-91	CONDUCTOR, CHIP (2012)	
JUMPER WIRE			
JW226	1-249-389-11	CARBON 4.7	5% 1/4W
JW280	1-249-385-11	CARBON 2.2	5% 1/4W
TRANSISTOR			
Q243	8-729-216-22	TRANSISTOR 2SA1162-G	
Q261	8-729-422-27	TRANSISTOR 2SD601A-Q	
Q262	8-729-422-27	TRANSISTOR 2SD601A-Q	
Q263	8-729-216-22	TRANSISTOR 2SA1162-G	
Q265	8-729-216-22	TRANSISTOR 2SA1162-G	
RESISTOR			
R212	1-249-440-11	CARBON 82K	5% 1/4W
R225	1-247-815-91	CARBON 220	5% 1/4W
R226	1-247-815-91	CARBON 220	5% 1/4W
R227	1-249-440-11	CARBON 82K	5% 1/4W
R228	1-216-033-00	METAL GLAZE 220	5% 1/10W
R229	1-216-025-91	METAL GLAZE 100	5% 1/10W
R230	1-216-033-00	METAL GLAZE 220	5% 1/10W
R231	1-216-022-00	METAL GLAZE 75	5% 1/10W
R232	1-216-022-00	METAL GLAZE 75	5% 1/10W
R233	1-216-065-00	METAL GLAZE 4.7K	5% 1/10W
R234	1-216-022-00	METAL GLAZE 75	5% 1/10W
R235	1-216-113-00	METAL GLAZE 470K	5% 1/10W
R236	1-216-065-00	METAL GLAZE 4.7K	5% 1/10W
R237	1-216-113-00	METAL GLAZE 470K	5% 1/10W
R238	1-216-065-00	METAL GLAZE 4.7K	5% 1/10W
R239	1-216-022-00	METAL GLAZE 75	5% 1/10W
R240	1-216-113-00	METAL GLAZE 470K	5% 1/10W
R241	1-216-065-00	METAL GLAZE 4.7K	5% 1/10W
R242	1-216-113-00	METAL GLAZE 470K	5% 1/10W
R243	1-216-065-00	METAL GLAZE 4.7K	5% 1/10W
R244	1-216-113-00	METAL GLAZE 470K	5% 1/10W
R245	1-249-417-11	CARBON 1K	5% 1/4W
R246	1-216-113-00	METAL GLAZE 470K	5% 1/10W
R247	1-249-417-11	CARBON 1K	5% 1/4W
R260	1-247-807-31	CARBON 100	5% 1/4W
R264	1-247-815-91	CARBON 220	5% 1/4W
R265	1-247-815-91	CARBON 220	5% 1/4W
R266	1-216-043-91	METAL GLAZE 560	5% 1/10W
R267	1-249-415-11	CARBON 680	5% 1/4W
R268	1-216-025-91	METAL GLAZE 100	5% 1/10W
R269	1-216-025-91	METAL GLAZE 100	5% 1/10W

REF.NO.	PART NO.	DESCRIPTION	REMARK
R270	1-216-041-00	METAL GLAZE 470	5% 1/10W
R271	1-249-415-11	CARBON 680	5% 1/4W
R272	1-249-417-11	CARBON 1K	5% 1/4W
R275	1-249-425-11	CARBON 4.7K	5% 1/4W
R276	1-249-425-11	CARBON 4.7K	5% 1/4W
R277	1-216-049-91	METAL GLAZE 1K	5% 1/10W
R279	1-216-025-91	METAL GLAZE 100	5% 1/10W
R280	1-216-033-00	METAL GLAZE 220	5% 1/10W
R281	1-216-033-00	METAL GLAZE 220	5% 1/10W
R282	1-216-025-91	METAL GLAZE 100	5% 1/10W
R283	1-216-025-91	METAL GLAZE 100	5% 1/10W
R284	1-216-065-00	METAL GLAZE 4.7K	5% 1/10W
R285	1-216-065-00	METAL GLAZE 4.7K	5% 1/10W
R286	1-216-049-91	METAL GLAZE 1K	5% 1/10W
R288	1-247-815-91	CARBON 220	5% 1/4W
R289	1-247-815-91	CARBON 220	5% 1/4W
R290	1-247-815-91	CARBON 220	5% 1/4W
R291	1-216-025-91	METAL GLAZE 100	5% 1/10W
R293	1-216-025-91	METAL GLAZE 100	5% 1/10W
R294	1-216-049-91	METAL GLAZE 1K	5% 1/10W
R301	1-249-417-11	CARBON 1K	5% 1/4W
R304	1-249-417-11	CARBON 1K	5% 1/4W

Note: The components identified by shading and mark Δ are critical for safety. Replace only with part number specified.

Note: Les composants identifiés par un trame et une marque Δ sont critiques pour la sécurité. Ne les remplacer que par une pièce portant le numéro spécifié.

<u>REF.NO.</u>	<u>PART NO.</u>	<u>DESCRIPTION</u>	<u>REMARK</u>
MISCELLANEOUS			
Δ	1-406-726-81	COIL, DEMAGNETIC (KV-29RS22C/29RS26C)	
Δ	1-411-899-11	COIL, DEMAGNETIC (EXCEPT KV-29RS22C/29RS26C)	
	1-452-032-00	MAGNET, DISC	
	1-504-531-11	SPEAKER (13.1X6.2CM)	
*	1-556-945-21	CABLE, P-P (KV-27S36)	
*	1-557-056-31	CABLE, P-P (KV-27S36)	
	4-052-905-01	V5/6 BRACKET (KV-27S36)	
	8-598-414-00	ANTENNA SWITCH AS-2F (KV-27S36)	
Δ	1-751-059-11	CORD, POWER (WITH CONNECTOR) 10A/250V (EXCEPT KV-29RS22C/29RS26C)	
Δ	1-769-796-41	CORD, POWER (WITH CONNECTOR) 10A/125V (KV-29RS22C/29RS26C)	
Δ	8-451-275-42	DEFLECTION YOKE Y28PFA	
Δ	8-733-848-05	CRT 29PXD (SD-268) (EXCEPT 29RS22C/29RS26C)	
Δ	8-733-849-05	CRT 29PXD (SD-268) (29RS22C/29RS26C)	
Δ	1-453-207-11	TRANSFORMER ASSY, FLYBACK (NX-2609//X4C)	
ACCESSORIES AND PACKING MATERIALS			
	3-859-518-21	MANUAL, INSTRUCTION (KV-27S26/27S36)	
	3-859-518-23	MANUAL, INSTRUCTION (KV-27S22)	
	3-859-518-41	MANUAL, INSTRUCTION (29RS26/29RS26C)	
	3-859-518-43	MANUAL, INSTRUCTION (KV-29RS22/29RS22C/29SD2/29PS2)	
*	4-041-277-01	INDIVIDUAL CARTON (KV-27S22/27S26/27S36)	
*	4-048-944-01	INDIVIDUAL CARTON (KV-29RS22/29RS22C/29RS26/29RS26C)	
*	4-060-350-01	INDIVIDUAL CARTON (KV-29SD2)	
*	4-060-351-01	INDIVIDUAL CARTON (KV-29PS2)	
*	4-041-255-01	BAG, PROTECTION	
*	4-052-382-01	CUSHION (UPPER) (ASSY)	
*	4-052-383-01	CUSHION (LOWER) (ASSY)	
REMOTE COMMANDER			
	1-473-748-31	REMOTE COMMANDER (RM-Y135A) (KV-27S22/29RS22/29RS22C/29SD2/29PS2)	
	1-473-749-31	REMOTE COMMANDER (RM-Y136A) (KV-27S26/27S36/29RS26/29RS26C)	
	4-978-977-01	LID, BATTERY COVER (for RM-Y135A/136A)	

9-965-833-01

Sony Corporation
Sony Technology Center
Product Quality Division
Service Promotion Department

English
97FJ74395-1
Printed in U S A
© 1997 6